



THE HIGHWAYS AGENCY

TD 40/94



THE SCOTTISH OFFICE DEVELOPMENT DEPARTMENT



THE WELSH OFFICE
Y SWYDDFA GYMREIG



THE DEPARTMENT OF THE ENVIRONMENT FOR
NORTHERN IRELAND

Layout of Compact Grade Separated Junctions

Summary: This Standard sets out the layout requirements for compact grade separated junctions. It gives recommendations for the application of compact grade separation to existing at grade junctions and to new routes incorporating junctions of this type.

REGISTRATION OF AMENDMENTS

Amend No	Page No	Signature & Date of incorporation of amendments	Amend No	Page No	Signature & Date of incorporation of amendments

REGISTRATION OF AMENDMENTS

Amend No	Page No	Signature & Date of incorporation of amendments	Amend No	Page No	Signature & Date of incorporation of amendments

PART 5

TD 40/94

**LAYOUT OF COMPACT GRADE
SEPARATED JUNCTIONS**

Contents

Chapter

1. Introduction
2. Design Procedure
3. Safety
4. Specific Road User Requirements
5. Flow Standards
6. Geometric Standards
7. Layout Options
8. References
9. Enquiries

1. INTRODUCTION

General

1.1 This Standard sets out the design standards and methodology for the geometric layout of compact grade separated junctions principally for use on rural and inter-urban roads. It is intended that the standard shall be used in those situations which are not appropriate to the full levels of provision covered in **TD 22 (DMRB 6.2.1)**.

1.2 It has been found that grade separation to the standards contained in **TD 22 (DMRB 6.2.1)** and **TA 48 (DMRB 6.2.2)** can be economically justified at design flows above 30,000 AADT on the main line, depending on turning traffic. Previously, using standards contained within **TA 20 (DMRB 6.2)**, it has normally been possible to justify grade separation to lower design flows of 20,000 AADT on the main line, but again this depended on turning traffic.

1.3 Grade separation should be considered wherever it can be economically justified and environmental constraints can be satisfied. Guidance on the process of choosing a junction type is given in **TA 30 (DMRB 5.1)**. Using those standards compact grade separation as set out here can be justified at flows as low as 12,500 AADT on single lane dual mainline depending on turning traffic and more significantly, accident rates. Attention should be paid to ensuring that there are no major differences in the level of junction provision along a route.

1.4 This standard therefore sets out the level of provision to be considered for low traffic flow situations on the minor road and effectively extends downwards the range of flows and conditions over which grade separation could well be justified economically to around 12,500 AADT on the through route. Further not readily apparent benefits may accrue in accident reductions at other crossings and rights of way, further reduction in severance and the compensation needed to alleviate it, and a reduction in the provision of accommodation bridges.

1.5 Full grade separation on a single carriageway as a general rule is not recommended for reasons of driver perception and therefore reduced safety and should generally be avoided in design. However **TD 9 (DMRB 6.1.1)** makes recommendations about the provision of grade separation at specific junctions on single carriageway roads. The provision of compact grade separations on single carriageways is a permitted alternative provided that the junction layout includes a section of single lane dualling on the mainline.

1.6 Comparisons of the overall size and layouts of grade separated junctions designed to **TD 22** and this standard are indicated in **Figure 1/1**.

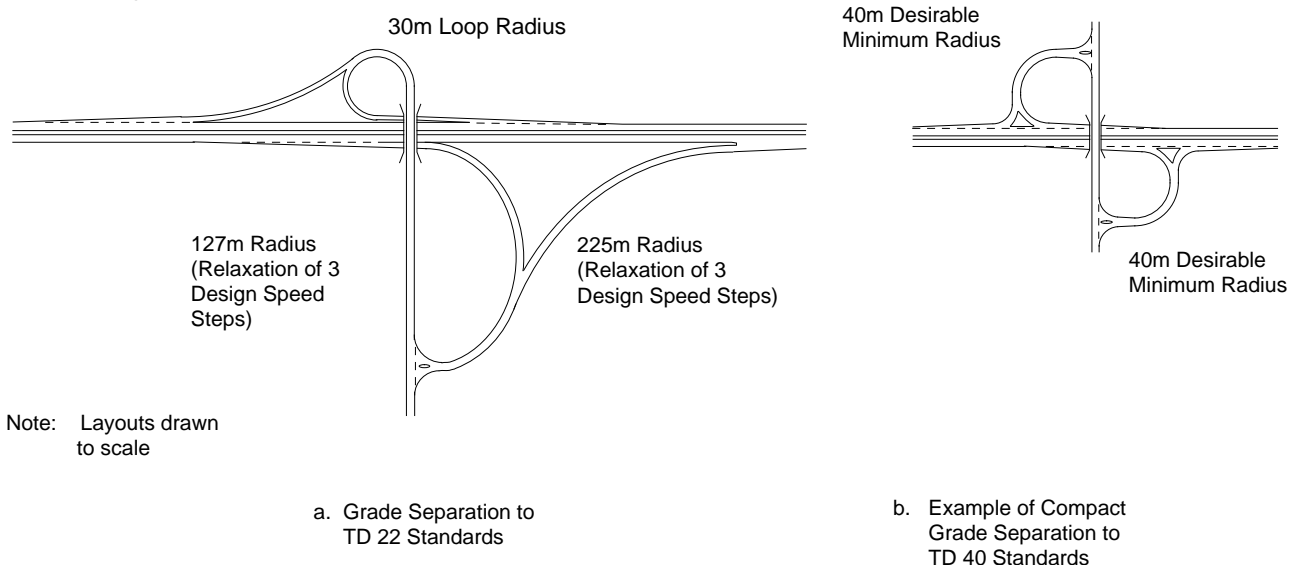

Figure 1/1 Examples of the range of Grade Separations

Principal Objectives

1.7 The objectives of compact grade separation can be said to be to:-

- a. improve safety by reducing the number and severity of accidents;
- b. provide a safer means of crossing high speed routes for all road users;
- c. reduce the environmental impact of grade separated junctions by providing a compact junction layout;
- d. regulate and maintain vehicle speed for minor route traffic through the junction at a level appropriate to the layout standards;
- e. extend the use of grade separation;
- f. remove right turn manoeuvres from high speed roads.

and specifically:-

- g. minimise land take;
- h. provide an operationally efficient junction layout;
- i. provide an economic solution for the modification of existing junctions to grade separation standards.

Scope

1.8 This standard sets out the layout requirements for new compact grade separated junctions and for the upgrading of existing at grade junctions.

1.9 Recommendations are given on the siting of the junctions, flow standards, layout alternatives, geometric design and safety for all classes of road users. Some aspects of signs and road markings are included for completeness, though the full policy and detailed guidance on these matters are given in the **Traffic Signs Manual**.

1.10 This standard also gives recommendations for the identification of existing junctions to which compact grade separation may be applied.

Implementation

1.11 This Standard should be used forthwith for the design of all schemes for the construction and improvement of trunk roads currently being prepared providing that, in the opinion of the Overseeing Organisation, this would not result in significant additional expense or delay progress. Design organisations should confirm its application to particular schemes with the Overseeing Organisation.

Definitions

1.12 The terminology follows where possible the definitions contained in **BS 6100: Subsection 2.4.1:1990**, and in **TD 22 (DMRB 6.2.1)**.

1.13 The following additional terms have been defined for use in this Standard.

Compact Grade Separated Junction: A grade separated junction designed in accordance with this standard.

Compact Connector Road: In the context of compact grade separated junctions a two way connector road between the major and minor roads.

1.14 Where the term Full Grade Separation is used in this standard it refers specifically to the standards contained in **TD 22 (DMRB 6.2.1)**. Grade Separation refers to both full and compact types of grade separation.

Mandatory Sections

1.15 Sections of this document are highlighted by being in boxes. These contain mandatory standards which the Overseeing Organisation expects in design. These are the sections with which the Design Organisation must comply or must have agreed a suitable departure from standard with the relevant Overseeing Organisation. The remainder of the document contains advice and enlargement which is commended to designers for their consideration.

2. DESIGN PROCEDURES

General Principles

2.1 The introduction of design standards for compact grade separation is primarily aimed at improving safety for all road users. At all stages in the design and construction of the junction it is of paramount importance that safety aspects are fully investigated and considered.

2.2 This standard shall be applied in the design process to both the improvement of existing at grade junctions on single and dual carriageways, and to the design of junctions on new single and dual carriageway routes. Compact grade separation requires in all cases the provision of either a section of single lane dualling or a full dual carriageway on the major route.

2.3 The standards for compact grade separation have in most instances been rigorously set in order to minimise the variation in designs to prevent confusion for the road user. Those items which do permit a degree of variation at the discretion of the designer are:

- a. Junction configurations;
- b. Horizontal radii on compact connector road (*desirable minimum radius with a relaxation of one design speed step*)
- c. Vertical Curvature; (*desirable minimum radius with a relaxation of one design speed step*)
- d. Carriageway Width; (*three options and a one step relaxation*)
- e. Curve Widening. (*three options are permitted for each radius*)

Junction Strategy

2.4 Junction design shall provide an understandable progression of standards for the driver and therefore sequences of junctions should not involve many different layout types. The introduction of a

compact grade separation to replace an existing at grade junction will have an effect within the route, beyond the immediate limit of the junction. It is therefore essential to assess the effect upon the network and prepare a junction strategy. The siting of the compact grade separated junction will require careful consideration of the degree of access to be provided.

2.5 On **existing single carriageways** compact grade separation may be applied to a route which consists of a number of priority junctions. The existing priority junctions may consist of a range of layouts from simple T junctions to staggered single lane dualling with priority junctions.

2.6 On **existing dual carriageways** the provision of compact grade separation may be applied to a route which consists of a number of grade separated junctions and roundabouts interspersed with major/minor at grade priority junctions. Introduction of compact grade separation on a route such as this is intended to remove all of the right turn manoeuvres associated with the mainline resulting in a fully grade separated route. Some left-in/left-out junctions may be retained or introduced.

2.7 Where a compact grade separated junction or junctions are being considered the following matters shall be taken into account:-

- a. the closure of certain minor road junctions which have very low flows and for which there are alternative routes. The additional journey length, delay and inconvenience resulting from the closure of a route must be considered in the context of the improved safety which will be achieved by the removal of all the right turn manoeuvres;
- b. limiting remaining at grade junctions to left in left out only;
- c. where there is no alternative route it may be necessary to reconsider the location and number of junctions;

- d. improvements to the network to assist the closure of certain junctions;
- e. the provision of accommodation roads, cycleways, footpaths and bridleways;
- f. the removal of agricultural accesses from the mainline;
- g. collecting a number of minor roads into a single compact grade separated junction;
- h. connecting minor roads or accommodation roads directly onto the compact connector road.

The Design Process

2.8 The design process for a compact grade separation shall be based upon the flow chart in **Figure 2/1**. The flow chart indicates the design process for the improvement of an existing priority junction to compact grade separation. The flow chart can be adapted for comparison of alternative junction options on a new route, and in this case the accidents, flows and turning proportions would be predicted rather than actual.

2.9 The design process may be applied to a junction in isolation or to a series of junctions within a route.

2.10 Low and high growth design year traffic flows may be derived from the traffic model (The **Traffic Appraisal Manual** (TAM) refers in England, Wales and Northern Ireland, and in Scotland the **Scottish Traffic and Environmental Appraisal Manual** (STEAM) refers).

2.11 In assessing the capacity and delays associated with a compact grade separated junction it is important to consider each of the individual elements which comprise the layout, particularly the additional priority junctions and the compact connector roads.

2.12 The introduction of compact grade separation will result in increased distances travelled for certain traffic movements due to the addition of the compact connector roads. The additional time taken should therefore be assessed throughout the day.

2.13 It can reasonably be assumed that delays at the junctions will only occur during the peak periods.

2.14 In assessing the accident rates associated with a compact grade separated junction it is important to predict the accident rates at each of the individual junction entry and exits within the compact grade separation.

2.15 No statistical information is presently available specifically for accident rates at compact grade separations or priority junctions restricted to left turn manoeuvres only. The removal of the right turn manoeuvre from the mainline junction and the provision of a central reserve should result in a decrease in the number and severity of accidents thereby achieving significant benefits. Guidance is provided in **Chapter 3** regarding the factors to be considered in the assessment of accident rates.

2.16 Guidance is provided in **Chapter 4** regarding specific road user requirements which should be considered at this stage.

Junction Design

2.17 Junction entries and exits with the mainline shall be based upon the recommendations contained within **TA 20 (DMRB 6.2)** modified to remove all right turn manoeuvres associated with the mainline traffic. Right turn manoeuvres will effectively be relocated to the priority junctions on the minor road.

2.18 Nearside diverging and merging tapers should be provided on the mainline in accordance with **TA 20 (DMRB 6.2)**. Slip roads shall not be used at compact grade separation since compact connector roads are 2 way.

2.19 Alternative forms of junction layouts are provided in **Chapter 7**.

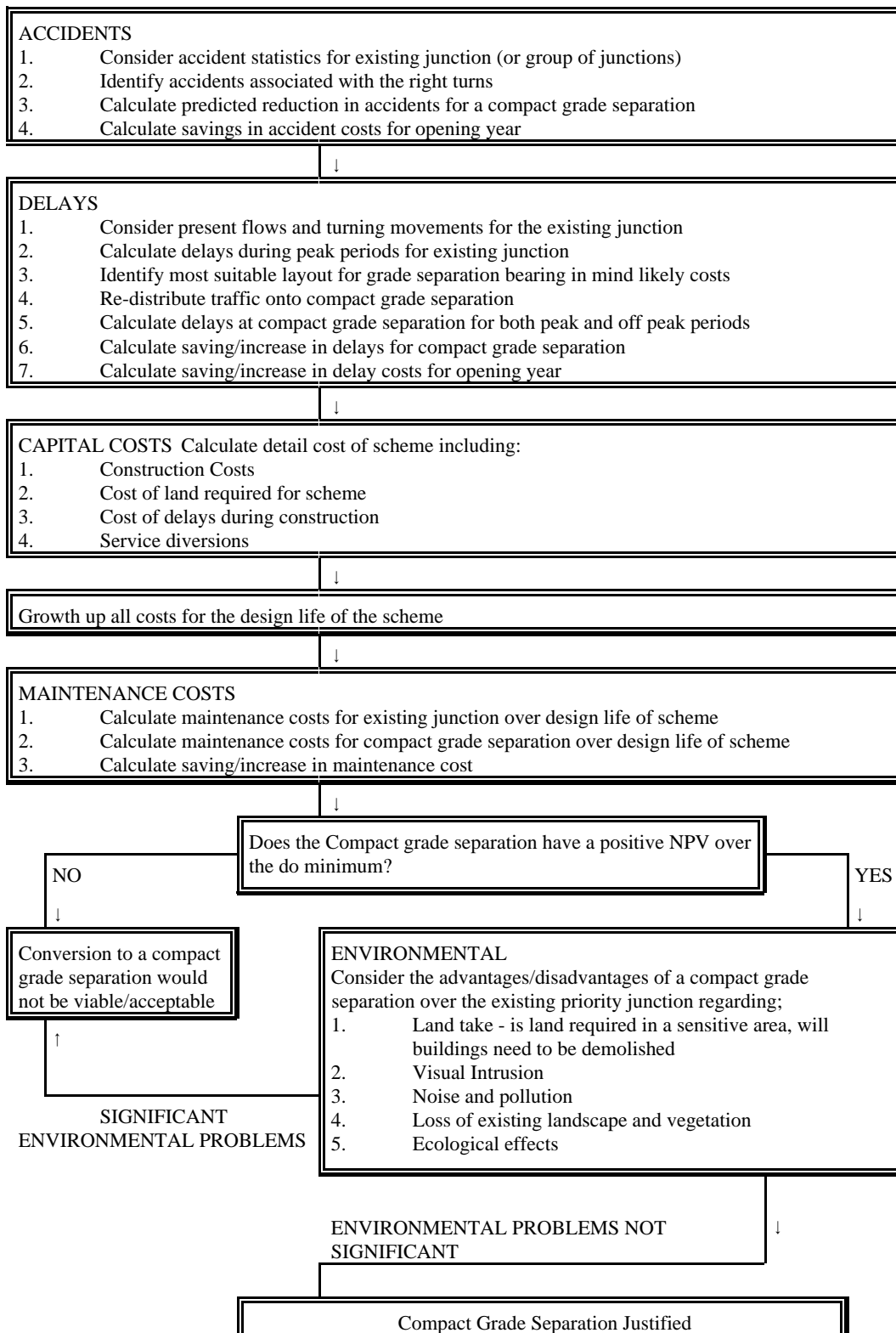

Figure 2/1 Upgrading of existing Priority junction to Compact grade separation.

Drainage

2.20 All drainage within the compact grade separated junction should be of a positive nature to facilitate the removal of surface water. Factors to consider and which may influence the decision are:-

- a. the geometric standards for the junction are likely to result in steep gradients combined with successive application and removal of superelevation up to 5%;
- b. surface water from the compact connector road should be prevented from flowing onto or across the major and minor carriageways.

Economic Assessment

2.21 The economic assessment of compact grade separation is particularly sensitive to the effects of traffic flows, traffic distribution and the junction layout:-

- a. capital costs are significantly affected by the structure, earthworks and pavement costs. It is therefore important that the opportunities for narrower bridges are fully examined, using narrow carriageways and verges;
- b. significant benefits can be achieved by the reduction in accident rates and severity by the removal of right turn manoeuvres from the mainline. The redistribution of traffic may require additional priority junctions between the compact connector road and the minor road. The accident rates for these junctions will need to be assessed and the benefits adjusted accordingly;
- c. the effect of providing grade separation will generally be a slight reduction in the delays associated with the at grade junctions. However the benefits will generally be outweighed by the additional time taken by some traffic through the compact grade separated junction, resulting from the redistribution of traffic onto the compact connector road. It is therefore important to optimise the compact grade separation layout to suit the traffic flow conditions and minimise the disbenefits associated with the delays;
- d. the costs arising from maintenance need to be taken into account.

2.22 It is recognised that in certain circumstances the use of **COBA** is not appropriate where the improvements are too fine in scale to be measured by the built-in traffic engineering formulae. For an individual compact grade separation it is recommended that a manual economic assessment be carried out. The procedures outlined here are based on those used for small Trunk Road scheme assessment as outlined on the Department of Transport form **ROADS 502**. In Scotland the use of **NESA** is recommended in preference to manual assessments.

Accident Costs

2.23 To determine the accident benefits it is necessary to predict the number of accidents at each of the proposed junction entries and exits within the compact grade separation and the compact connector roads based upon the redistributed traffic flows. These are then compared with the recorded accident rates at the existing at grade junction taken over a minimum of 3 years.

2.24 In assessing the accident rates for left turn only (**restricted**) entry and exits it can be assumed that the predicted accident rate will be 25% of that calculated for a junction at which all movements are permitted. The calculations should include redistributed traffic flows from adjacent junctions whose movements have been subsumed into the new layout. The accident rates for the un-restricted movements at the junction entries and exits with the minor road must be calculated and included without adjustment.

2.25 From **Table 3/1 in Chapter 3** the severity ratios for each of the individual junction entries and exits can be determined for the road classification and speed limit and applied to the predicted accident rates to calculate the number and severity of accidents.

2.26 From **Road Accidents in Great Britain (The Casualty Report)** the average cost per accident by severity can be obtained, and the severity ratios and average costs per accident for the various classification of road may be calculated at each of the junction entries and exits.

Value of Time

2.27 To determine time savings (or increases) calculate the total vehicle hours saved (or lost) in the scheme opening year using both high and low traffic/economic growth:-

- a. calculate average time savings (or increases) per vehicle for peak and off-peak periods. This will necessitate the calculation of the average time taken through the various links of the grade separated junction making allowances for acceleration and deceleration;
- b. calculate the delays at the junction entries and exits during the peak periods;
- c. factor the savings (or increases) per day in order to arrive at an annual time saving (or increase) by using the appropriate **M Factor** and **value of time (VOT)** obtained from **COBA (NESA in Scotland)**.

2.28 If the local mix of traffic should differ significantly from the trunk road average then the value of time appropriate to the local traffic mix can be substituted.

Vehicle Operating Costs

2.29 Compact grade separation can increase significantly the total vehicle kilometres travelled due to the reassignment of the traffic through the compact grade separation. The total additional distance for each movement and the annual vehicle operating costs can then be determined.

Calculation of Present Value of Benefits

2.30 The accident, time and vehicle operating costs calculated for the scheme opening year (both high and low growth) should each be capitalised over 30 years and discounted back to the base year to give the present value of benefits (**PVB**).

3. SAFETY

General

3.1 One of the principal objectives of compact grade separated junction design is to improve safety by the elimination of right turn manoeuvres between the mainline and the side road, by providing left turn only priority junctions and the closure of central reserve gaps.

3.2 There is no definitive information providing accident statistics for left turn only priority junctions. Investigation of accidents at 3 arm priority junctions indicate that 68% of accidents are directly attributable to right turn manoeuvres, 19% are directly attributable to left turn manoeuvres and the remaining 13% are attributable to either both combined or other factors. Removal of the right turn and the provision of a central reserve would most probably reduce the accident rate by 75% by the removal of certain conflicting manoeuvres.

3.3 The layout of the compact grade separation will however lead to accidents at the junctions between the compact connector road and the minor road which will

cater for all turning manoeuvres. Taking into account accident records, and the lower level of flows through the junctions with the minor road, it is possible to estimate what the accident distribution might be. The combined effect suggests that the number of accidents at 3 arm priority junctions can be reduced by approximately 50% and by approximately 75% at 4 arm priority junctions, by the introduction of compact grade separation.

3.4 Accident statistics for 3 arm priority junctions indicate that the severity of accidents is dependent upon the classification of the mainline and the mainline speed limit and that generally accident severity decreases as speed decreases. Compact grade separation will transfer the right turn manoeuvres from the higher speed, higher classification road to the lower speed, lower classification road. The effect of this will be to reduce the number of fatal and serious accidents with a corresponding increase in slight accidents as indicated in **Table 3/1**. This information can then be used as a basis to calculate the average cost/accident for the conditions applicable at each of the junction mouths.

Classification of Road	Accident Severity	Speed Limit (mph)				
		30	40	50	60	70
A	Fatal	1527 (1.27)	422 (2.28)	64 (3.64)	740 (3.03)	239 (5.31)
	Serious	22607 (18.82)	3994 (21.62)	384 (21.87)	5493 (24.37)	1220 (27.11)
	Slight	95962 (79.91)	14058 (76.1)	1308 (74.49)	17702 (72.6)	3042 (67.58)
B	Fatal	515 (1.22)	56 (1.57)	4 (1.79)	154 (2.12)	
	Serious	7965 (18.85)	785 (21.99)	52 (23.32)	1707 (23.52)	
	Slight	33766 (79.93)	2728 (76.44)	167 (74.89)	5396 (74.36)	
C	Fatal	326 (1.07)	30 (2.25)	0 (0)	80 (2.12)	
	Serious	5712 (18.73)	287 (21.56)	8 (16.67)	823 (21.77)	
	Slight	24461 (80.20)	1014 (76.19)	40 (83.33)	2877 (76.11)	
Unclassified	Fatal	995 (0.88)	41 (1.63)	3 (2.65)	74 (1.61)	
	Serious	21127 (18.69)	566 (22.43)	28 (24.78)	1018 (22.14)	
	Slight	90912 (80.43)	1916 (75.94)	82 (72.57)	3505 (76.25)	

Table 3/1 Numbers and Percentages (%) of Personal Injury Accidents for 3 Arm Priority Junctions (extracted from STATS 19 Database, 1987 - 1991)

3.5 Taking into account the reduction in the predicted number of accidents and the reduction in accident severity ratios, evidence suggests that annual accident costs for 3 arm priority junctions can be reduced by approximately 60% and for a 4 arm priority junction by approximately 80%, by the introduction of compact grade separation.

3.6 It is intended that compact grade separation shall be used to provide a safe means of crossing high speed routes for all road users, and specific requirements are detailed in **Chapter 4**. The geometrical standards for the compact connector road have been established at a level of provision intended to maintain slow vehicular speeds through their length thereby improving safety for other road users.

3.7 Other positive factors which improve safety as a result of compact grade separation are;

- a. removing the possibility of large vehicles which cross central reserve gaps protruding into the offside lane;
- b. removal of U turns on the mainline.

Traffic Signs / Road Markings

3.8 The provision and layout of traffic signs and road markings is an integral part of the junction design process and shall be considered at an early stage. Advance direction and warning signs shall be provided on both the major and minor roads. Positioning of signs within the junction and the compact connector road shall be carefully considered so that they do not interfere with driver's visibility. It is essential that there is no over-provision of signing within the compact connector road which may result in unnecessary distractions to drivers negotiating the curves.

3.9 On the approach to the junction from either the major or minor road the junction must be clearly defined by means of appropriate signing indicating the junction as a priority T junction and not as a slip road.

3.10 Where full curve widening is not provided, as identified by paragraphs 6.20, 6.21 and Table 6/3, then regulatory signs shall be provided in accordance with **Chapter 3 of the Traffic Signs Manual** on the compact connector road to advise motorists in one direction that they should give way to vehicles proceeding in the opposite direction. Statutory requirements for regulatory signs are contained in the **Traffic Signs Regulations and General Directions and Traffic Signs Regulations (Northern Ireland)**.

3.11 Within the compact connector road it is recommended that signing be restricted to warning signs indicating the nature of the alignment, and the proximity of junctions.

3.12 The application of special surface treatments may be provided as an additional means of highlighting the nature of the geometrical standards for the compact connector road. This can be achieved by the application of a contrasting surface colour (red) within the hatch markings to emphasise the nature of the curve, this should reinforce the meaning and presence of the markings to the driver.

Surfacing

3.13 Given the possibility of steep gradients on the approach to the junctions consideration should be given to the properties of the surfacing particularly with regard to skid resistance and wear.

4. SPECIFIC ROAD USER REQUIREMENTS

General

4.1 Compact grade separated junctions are intended to be used by all classes of road users. Detailed attention to the needs of the following classes of road user is required throughout the junction.

Pedestrians

4.2 The compact grade separation should be used to remove conflict between pedestrians and vehicles. If possible, separate pedestrian routes should be provided away from junction entry and exits although it is acknowledged that this is rarely practicable. Pedestrians should be encouraged to use the compact grade separation to cross the major road and excessive detours from their desired route should be avoided. Routes should therefore be provided through the grade separation to link existing footpaths or footways where the perceived level of usage by pedestrians justifies their inclusion. All footpaths should be clearly visible to drivers on the mainline or minor road carriageways to ensure that pedestrians will feel secure in using the facility.

Cyclists

4.3 Advice is available on the provision of facilities for cyclists in the following documents

- **TA 57 (DMRB 6.3)** - Roadside Features
- **Local Transport Note (1/86)** - Cyclists at Road Crossings and Junctions
- **Traffic Advisory Leaflet (1/88)** - Provision for Cyclists at Grade Separated Junctions
- **Cycling Advice Note 1/89** - Providing for the Cyclist - Cyclists at Road Crossings and Junctions - Shared Use by Cyclists and Pedestrians
- **Cycling Advice Note 1/90** - Making Way for Cyclists - Planning, Design and Legal Aspects of Providing for Cyclists

4.4 The compact grade separation should be used to remove conflict between cyclists and vehicles. Cyclists should be encouraged to use the compact grade

separation to cross the major road. To assist cyclists gradients would ideally be limited to 5%, however the objectives of compact grade separations will in many instances prevent this being achieved. Gradients should only be increased above this figure to those set out in **paragraph 6.15** with careful consideration of all factors.

4.5 Where regular usage by both pedestrians and cyclists is identified then consideration should be given to combined facilities.

4.6 Identification of usage should be carried out at an early stage in the design.

Equestrians

4.7 Identification of tracks and bridleways regularly used by equestrians should be carried out at an early stage of the design process.

4.8 Uncontrolled crossing of high speed carriageways by equestrians should be avoided and tracks and bridleways should be diverted onto the compact grade separation wherever possible. Equestrians can be expected to divert for moderate distances without undue inconvenience provided that the diversion takes no longer than a few extra minutes.

4.9 Where cattle grids are provided on the minor road approaches to a compact grade separation, manually operated gates should be provided adjacent to the grids for equestrians.

Use by Drivers of Agricultural Vehicles

4.10 It is intended that compact grade separations shall be used to accommodate the requirements for large, slow-moving agricultural vehicles. Careful consideration must be given to the combined effect of the gradient and superelevation to ensure that high loads are not subject to sudden shifts caused by rapid changes in crossfall.

4.11 Where farm or field accesses on the mainline are situated close to the compact grade separated junction consideration should be given to joining them to the compact connector road.

Use for Farm Animals

4.12 Where farms are adjacent to compact grade separated junctions it may be necessary to provide cattle grids on the minor road approach or on the accommodation road approach to the junction. Cattle grids should be sited in accordance with **TA 57 (DMRB 6.3)**.

Requirement for Hardened Verges

4.13 Where there is expected usage by a combination of equestrians, agricultural vehicles and farm animals, hardened verges should be considered on the compact connector road to prevent damage to the verge and drainage and to encourage these users to travel more safely and comfortably off the main carriageway.

5. FLOW STANDARDS

General

5.1 The introduction of compact grade separation is intended to extend downwards the range of flows and conditions over which grade separation may be considered. It has been found that using these standards improving existing junctions to compact grade separation can be justified down to flows of around 12,500 AADT on the mainline, depending upon turning traffic.

5.2 Compact grade separation can be used with single carriageways and dual two lane all-purpose roads within Categories 3A, 3B, 4, 5 & 6 of roads as defined in Table 4 of **TD 9 (DMRB 6.1.1)**.

Flow Levels

5.3 Compact grade separated junctions appear to be suitable for use where mainline flows are between approximately 12,500 AADT and 30,000 AADT and are normally associated with very low flows (generally below 10% of mainline flow) on the minor road.

Delays

5.4 Junction delay figures significantly in the economic assessment of alternative forms of junctions and is dependent upon the geometric standards and the traffic conditions. In assessing the delays associated with compact grade separations it is important to include the additional travelling time required to pass through the compact connector roads and to negotiate the additional junction entry and exits. Delays at the major/minor junctions may be significantly reduced during the peak periods; travel time throughout the day will increase due to the additional distance through the junction.

5.5 Alternative layout options for 4 arm junctions should be assessed to determine the most suitable form to minimise the additional delays, which will depend upon the turning proportions. This should be carried out at an early stage in the design when considering the topographical and environmental constraints imposed upon the junction location and form.

Capacity

5.6 Junction capacity is dependent upon the interaction between the various traffic movements within a junction and the geometrical standards of the junction. **TRRL Report SR582** provides guidance for the prediction of capacity based upon investigation of existing junctions. Analysis of capacities for compact grade separations based on this report indicates that the removal of the right turn manoeuvre can result in significant capacity increases.

5.7 In the particular case of 3 arm (T) junctions, conversion to compact grade separation is only likely to prove viable where the existing junction already experiences delay or the junction is an essential element of the route, possibly providing a means of removing right turn manoeuvres at adjacent 3 arm junctions as indicated in **Figure 7/8**.

5.8 Analysis indicates that for the improvement of an existing priority junction to compact grade separation standards an increase in capacity of 80% for some movements can be achieved at the mainline junctions.

5.9 The layout of the compact grade separation should be chosen to suit the traffic movements. In certain conditions the redistribution of the turning traffic can result in significant turning flows at the minor road junction entry and exits. It is important therefore to assess the capacity of these junctions when considering the layout to be adopted.

6. GEOMETRIC STANDARDS

General

6.1 This standard provides a geometric standard for compact grade separation incorporating established design standards for major/minor junctions. The geometric standards contained in **TD 9 (DMRB 6.1.1)** provide for design speeds down to a minimum of 50kph. The geometric standards for compact grade separation are generally based upon the principles contained in **TD 9 (DMRB 6.1.1)** but are for a design speed of 30 kph which is 3 design speed steps below the current minimum.

6.5 The design standards for compact grade separated junctions relate to a single design speed of approximately 30kph. Junctions shall only be designed to this design speed, higher or lower standards shall not be used. A range of standards would result in driver confusion and uncertainty and problems of perception of the junction with consequent safety implications.

6.2 The geometric standards for the mainline and for those minor roads which pass directly through a compact grade separation shall be provided in accordance with Standard **TD 9 (DMRB 6.1.1)**.

6.6 If speeds markedly in excess of this do occur or are anticipated then speed limits within the junction may need to be considered.

Design Speed

6.3 Design speeds for the mainline and the minor road shall be determined from **TD 9 (DMRB 6.1.1)**.

6.4 As a general principle it is intended that the speed of vehicles through the compact connector road shall be limited by its speed through the entry and exit junctions with the mainline and the minor road. For this reason long straight sections within the compact connector road shall be avoided.

Compact Connector Road

6.7 Compact connector roads shall be designed in accordance with **Table 6/1** except for the special conditions of **paragraph 6.11** when the stopping sight distance may be relaxed further as set out in paragraph 6.11. The stopping sight distances in **Table 6/1** are not related to the design speed but are based upon the requirements to provide adequate stopping sight distance through the compact connector road to show clearly to the driver leaving the mainline the shape of the junction.

STOPPING SIGHT DISTANCES	
Desirable Minimum (m)	70
Relaxation of One Design Speed Step (m)	50
HORIZONTAL CURVATURE	
Desirable Minimum Radius (m) with 5% Superelevation	40
Relaxation of One Design Speed Step(m) with 5% Superelevation	32
VERTICAL CURVATURE	
Desirable Minimum Crest K	3.3
Relaxation of One Design Speed Step Crest K	2.3
Absolute Minimum Sag K with lighting	2.3
Absolute Minimum Sag K without lighting	3.2

Table 6/1 Design Standards for Compact Connector Roads

Horizontal and Vertical Alignment

6.8 Horizontal radii shall comply with **Table 6/1**. In normal circumstances the Desirable Minimum Radius should be used, however in difficult circumstances a Relaxation of one design speed step may be used at the discretion of the Design Organisation.

6.9 Given the low design speed and the nature of the compact connector road, transition curves are not required within the compact grade separated junction.

6.10 In the design of vertical curves consideration is given to stopping sight distance and driver discomfort, which requires the vertical rate of change of grade to be kept within tolerable limits. For the low design speed adopted for compact connector roads the stopping sight distance criterion over the summit is not critical because larger changes of grade do not obstruct stopping sight distance and the comfort criterion overrides. Wherever possible vertical curvature on bridge decks should be avoided.

Sight Distances

6.11 Where the minor road continues on a direct alignment across the major road as indicated in **Figures 7/1 & 7/2** the stopping sight distances shall be in accordance with **TD 9 (DMRB 6.1.1)**. Where minor road through traffic is the principal user of the compact connector road as indicated in **Figure 7/3** the stopping sight distance may be decreased to a value based upon the design speed of 30kph as indicated in **Table 6/2**.

Desirable Minimum (m)	33
Relaxation of One Design Speed Step (m)	26

Table 6/2 Stopping Sight Distances based on the design speed of 30kph for Compact Connector Roads used principally by minor road through traffic

6.12 The stopping sight distances for compact grade separations have been set at a level intended to discourage high speeds. The standard is however greater than that required for the design speed adopted.

6.13 For the connections to the major and minor roads, guidance on sight distance and visibility standards are given in **TA 20 (DMRB 6.2)**. In the case of compact grade separation these shall be taken as mandatory.

6.14 Where minor roads or accommodation roads are connected to the compact connector road then the visibility standards at the junction shall be in accordance with **TA 20 (DMRB 6.2)** and **Table 6/1** of this standard.

Gradients

6.15 The desirable maximum gradient for compact connector roads shall be 8%, although relaxation to 10% shall be permitted in difficult locations. In selecting the gradient, the needs of cyclists should be considered (**paragraph 4.4**) and the risk of occurrence of icy conditions.

Superelevation

6.16 Normal standards for superelevation, set out in **TD 9 (DMRB 6.1.1)**, would require excessive superelevation for all compact grade separations. Icy conditions can cause slow moving vehicles to slide to the inside of the curves with excessive superelevation, this effect can be exacerbated by steep gradients.

6.17 The geometric layout of the compact connector road will require successive application and removal of the superelevation between the connector road and the junction mouths. The need to maintain consistent steering requirements through the compact connector road is an important design consideration which shall be taken into account in the application of superelevation.

6.18 Superelevation on compact connector roads shall be limited to 5%.

Cross Sections and Curve Widening

6.19 For the purpose of designing junctions and interchanges, cross sections for the mainline and all connector roads are given in the Manual of Contract Documents for Highway Works, Volume 3 "Highway Construction Details" (MCHW 3.1). Different lane marking details and widths of construction for compact connector roads from those shown in "Highway Construction Details" are specified in this standard.

6.20 Compact connector roads may be widened on curves in accordance with Table 6/3, the widening shall be applied in the form of central hatched markings as illustrated in Figure 6/1. The width of curve widening shall be chosen to suit the anticipated level of usage by large goods vehicles. Designers shall take into account the probability of large vehicles regularly meeting on the curve.

6.21 Where no curve widening is applied large goods vehicles will cut across into the oncoming lane, where the minimum curve widening is applied large goods vehicles will cut across into the whole of the hatched area. Where the normal curve widening is provided there will be sufficient width for two large vehicles to pass in opposite directions. Regulatory signs shall be provided when appropriate in accordance with paragraph 3.10.

Inner Channel Radius (m)	Width W_H of Hatching at Apex on Curve (m)		
	No Curve Widening	Minimum Curve Widening	Normal Curve Widening
40	0.6	1.90	3.40
32	0.6	2.54	3.74

Table 6/3 Curve Widening on Compact Connector Roads

6.22 Carriageway widths for the compact connector road shall be such that they provide a transitional change in standards from the major carriageway width to the minor carriageway width in accordance with Table 6/4.

6.23 The minimum width of carriageway for a compact connector road shall be 6.6m and the maximum shall be 7.9m, excluding curve widening. Where the traffic volumes are particularly low and the proportion of large goods vehicles is correspondingly low a relaxation to 6m may be permitted, by either reducing the carriageway width or omitting the central hatched markings.

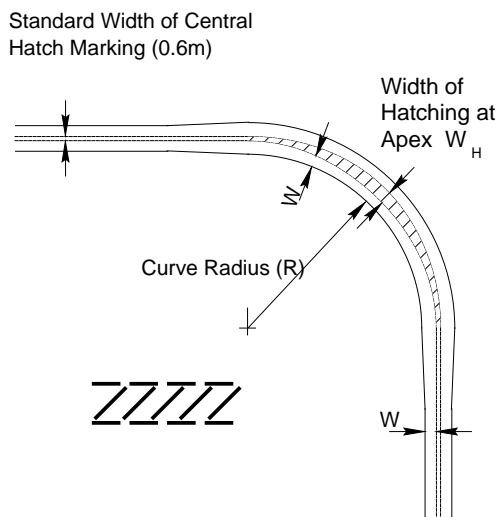

Figure 6/1 Application of Curve Widening

Major Carriageway	Compact Connector Road		Minor Carriageway
Lane Width (m)	Lane Width (W) (excluding hatching) (m)	Standard Width of Central Hatch Markings (m)	Lane Width (m)
All Widths	3.0	0.3 per lane	< 3.0
	3.3	0.3 per lane	3.0 to 3.65
	3.65	0.3 per lane	3.65

Table 6/4 Compact Connector Road Widths

6.24 A minimum width of 6m should also be provided adjacent to traffic deflection islands. In addition traffic deflection islands should be set back 1 metre from the give-way line at the junction with the mainline as shown in **Figure 6/2**.

Minor Road Width	x	y	z
< 3.0	3.0	0.6	4.7
3.0 to 3.65	3.3	0.6	4.7
3.65	3.65	0.6	4.7

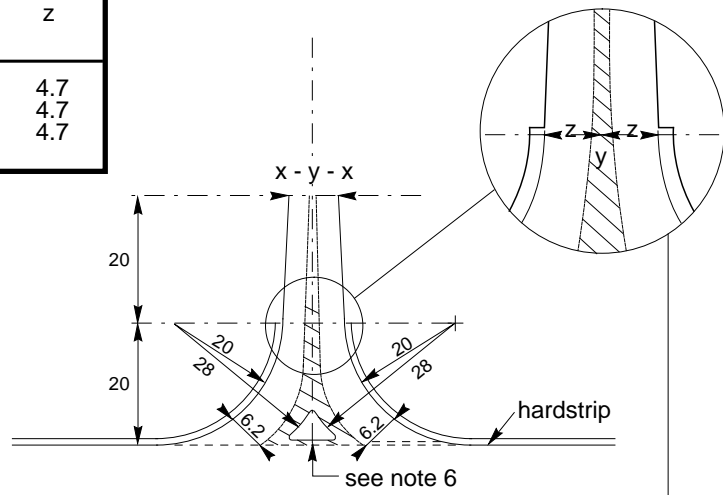

NOTES:

1. All dimensions are in metres.
2. All corner radii on islands are to be 0.7 - 1.0m radius.
3. These details apply to both single lane dual and D2AP carriageways.
4. For length of taper refer to TA 20 (DMRB 6.2).
5. Where required, junctions may have both a merging and diverging taper.
6. The minimum width adjacent to traffic islands is 6m (see paragraph 6.24)

a) SIMPLE MAINLINE JUNCTION

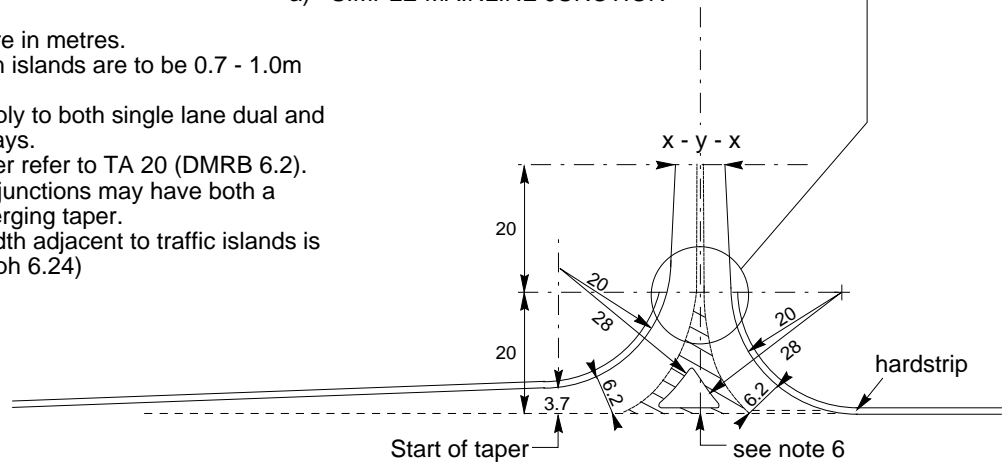

b) MAINLINE JUNCTION WITH NEARSIDE DIVERGE TAPER

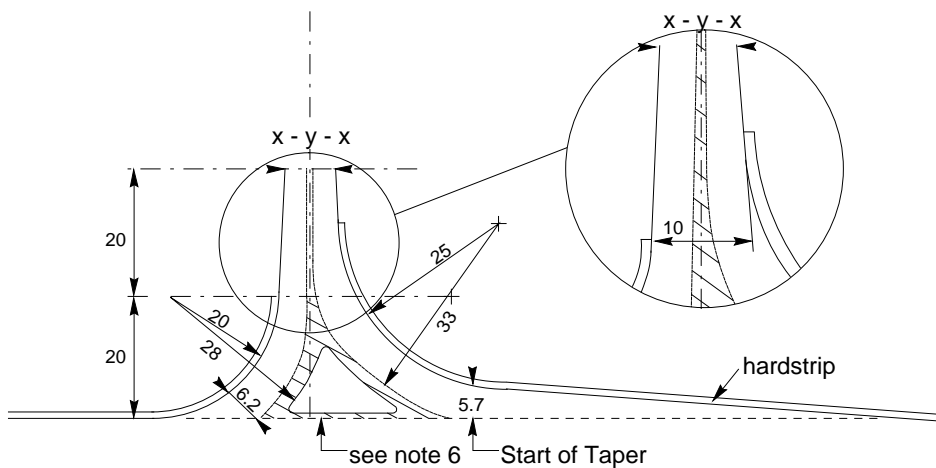

c) MAINLINE JUNCTION WITH NEARSIDE MERGING TAPER

Figure 6/2 Modified Major/Minor Junction for Left Turn Only Manoeuvres

(Dimensions are those set out in TA 20 (DMRB 6.2) but modified for left in/left out operation. As modified in paragraph 6.29, the conditions under which tapers may be provided are detailed in TA 20 (DMRB 6.2))

6.25 The length of solid island in the single lane dualling section shall be of the minimum length necessary to prevent right turn manoeuvres. U turns shall be banned at either end of the single lane dualling.

Channelising Islands

6.30 All channelising islands associated with the junction of the mainline and the compact connector road shall be physical islands to ensure separation of traffic and to prevent vehicles attempting right turns.

Hardstrips

6.26 The use of hardstrips is associated with high speed roads, they shall not be used within the compact connector road. Where hardstrips are included on the mainline they shall be terminated within the junction as indicated in **Figure 6/2**.

Junctions

6.27 Junction entries and exits with the mainline shall be based upon the standards contained within **TA 20 (DMRB 6.2)** modified to remove all right turn manoeuvres associated with the mainline traffic. Right turn manoeuvres will effectively be relocated at the priority junctions on the minor road.

6.28 The modified junction layouts for the left in, left out junctions are indicated in **Figure 6/2**.

Merges and Diverges

6.29 Nearside diverging and merging tapers shall be provided in accordance with the directions given in **TA 20 (DMRB 6.2)**. The provision of merging and diverging tapers shall be carefully considered giving particular regard to the following factors:-

- a. proportion of merging and diverging traffic, generally in excess of 100 vehicles per day;
- b. visibility standards at the junctions;
- c. the gradient of the roads and their effect on speed and acceleration;
- d. the proportion of slow moving vehicles;
- e. the cost of provision.

Footpaths

6.31 Where footpaths, footways or combined facility or combined footpath/cycleways are to be provided, in accordance with **Chapter 4**, a minimum width of 1.5m is permitted.

7. LAYOUT OPTIONS

General

7.1 The layout for the compact grade separation will in many cases be dictated by the constraints imposed by the existing junction to be modified, or site topography in the case of new routes. The formats of these junctions are numerous and it is not possible to provide exhaustive examples. In some cases, underbridges could be considered as an alternative and they may prove practical and justifiable economically. There may be situations, where, due to local topography, this would be preferable in landscape terms. In level and treeless landscapes, overbridges can be visually intrusive and planting may be out of character. Environmental Design is addressed further in **DMRB Volume 10, The Good Roads Guide**.

7.2 Detailed examples of 3 alternative layouts for 4 arm junctions are indicated in **Figures 7/1 to 7/3** and an example of a layout for a 3 arm junction is indicated in **Figure 7/4**. Schematic representations of other layouts are indicated in **Figures 7/4 to 7/8**.

7.3 **Figure 7/9** indicates two method of incorporating a compact grade separation into a section of carriageway which has a series of priority junctions in close proximity. The first option indicates the junctions adjacent to the compact grade separation restricted to left in left out requiring right turning traffic from these junctions to divert to the compact grade separation to complete their manoeuvre. The second option indicates the closure of the adjacent priority junctions and the total diversion of these routes to connect into the compact grade separated junction.

7.4 The preferred locations for the junction of the compact connector road to the mainline are in the 1st and 3rd quadrants as indicated in **Figures 7/1, 7/2 and 7/4**, as they facilitate the provision of required visibilities without the need to widen under the structure.

Typical Sketch Layouts

Figure 7/1 Detailed layout of 4 arm, D2AP carriageway with compact connector roads in preferred location and including both merging and diverging tapers, and free flow on the minor carriageway. For junctions where

minor road traffic movement is primarily straight across.

Figure 7/2

Detailed layout of 4 arm, D2AP carriageway with compact connector roads in preferred location without merging and diverging tapers, and free flow on the minor carriageway. For junctions where minor road traffic movement is primarily straight across.

Figure 7/3

Detailed layout of 4 arm, D2AP carriageway with compact connector road forming a loop. For junctions where minor road traffic movement is primarily turning onto and off the major carriageway.

Figure 7/4

Detailed layout of 3 arm, D2AP carriageway with compact connector roads in preferred location and including both merging and diverging tapers.

Figure 7/5

A selection of schematic layouts indicating 4 arm compact grade separations on dual all-purpose carriageways.

Figure 7/6

A selection of schematic layouts indicating 4 arm compact grade separations on single all-purpose carriageways.

Figure 7/7

A selection of schematic layouts indicating 3 arm compact grade separations on dual all-purpose carriageways.

Figure 7/8

A selection of schematic layouts indicating 3 arm compact grade separations on single all-purpose carriageways.

Figure 7/9

Schematic example of compact grade separation and restricted junctions.

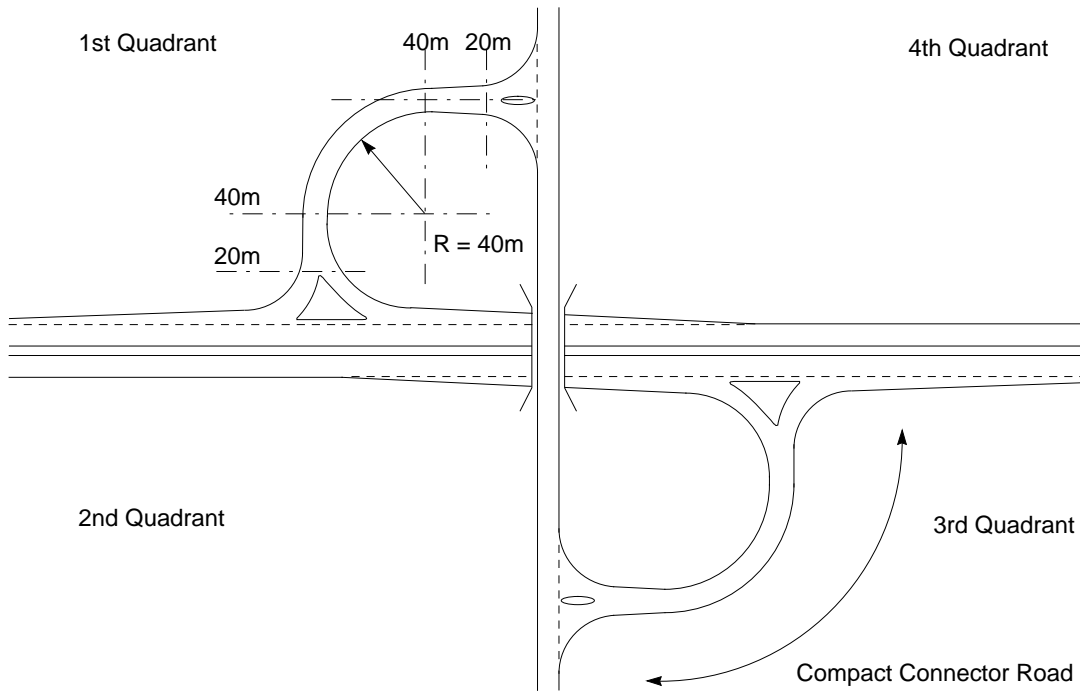

Figure 7/1 Example of Compact Grade Separation for 4 Arm Junction, Showing Merge and Diverge Tapers

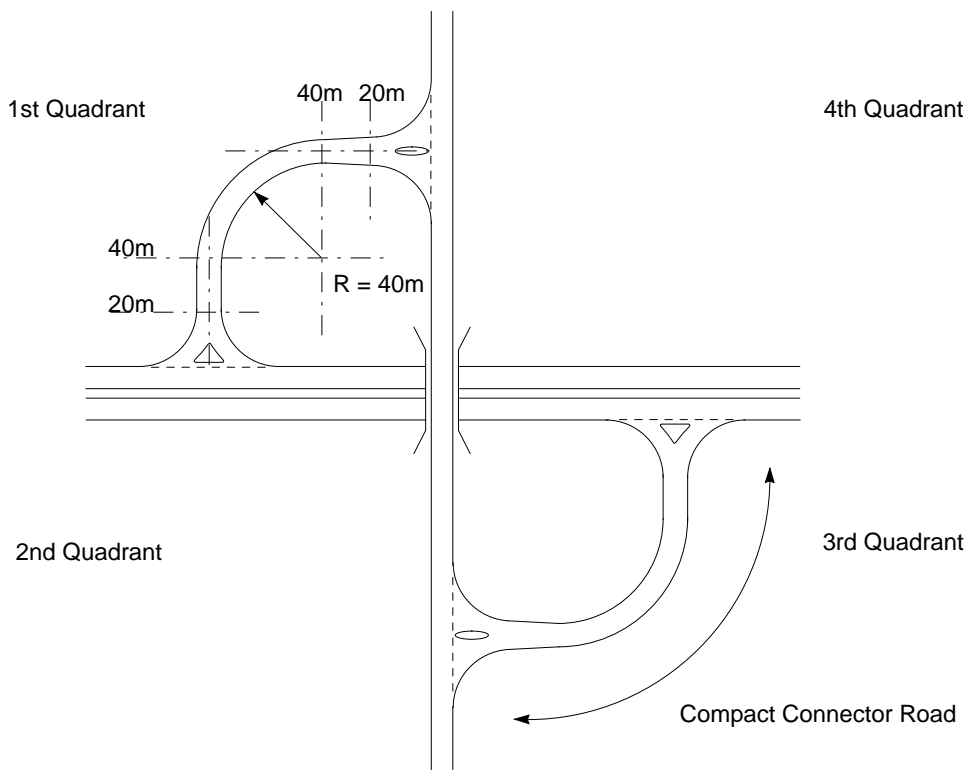

Figure 7/2 Example of Compact Grade Separation for 4 Arm Junction, Without Merge and Diverge Tapers

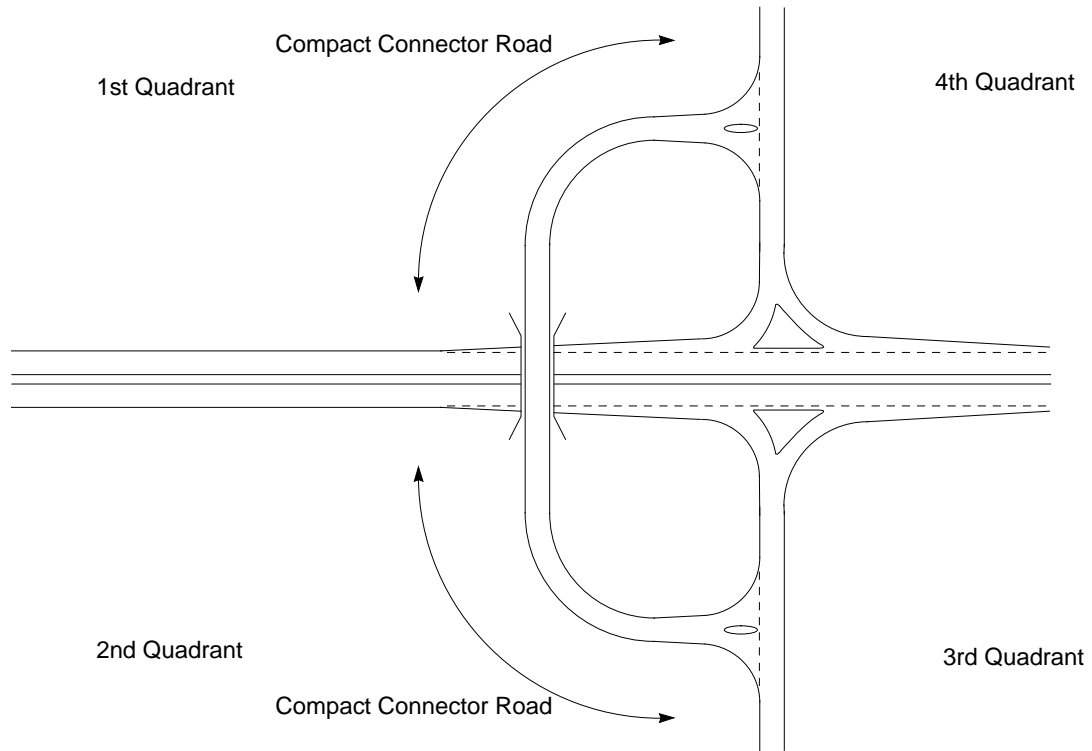

Figure 7/3 Compact Grade Separation for 4 Arm Junction, Showing Merge and Diverge Tapers

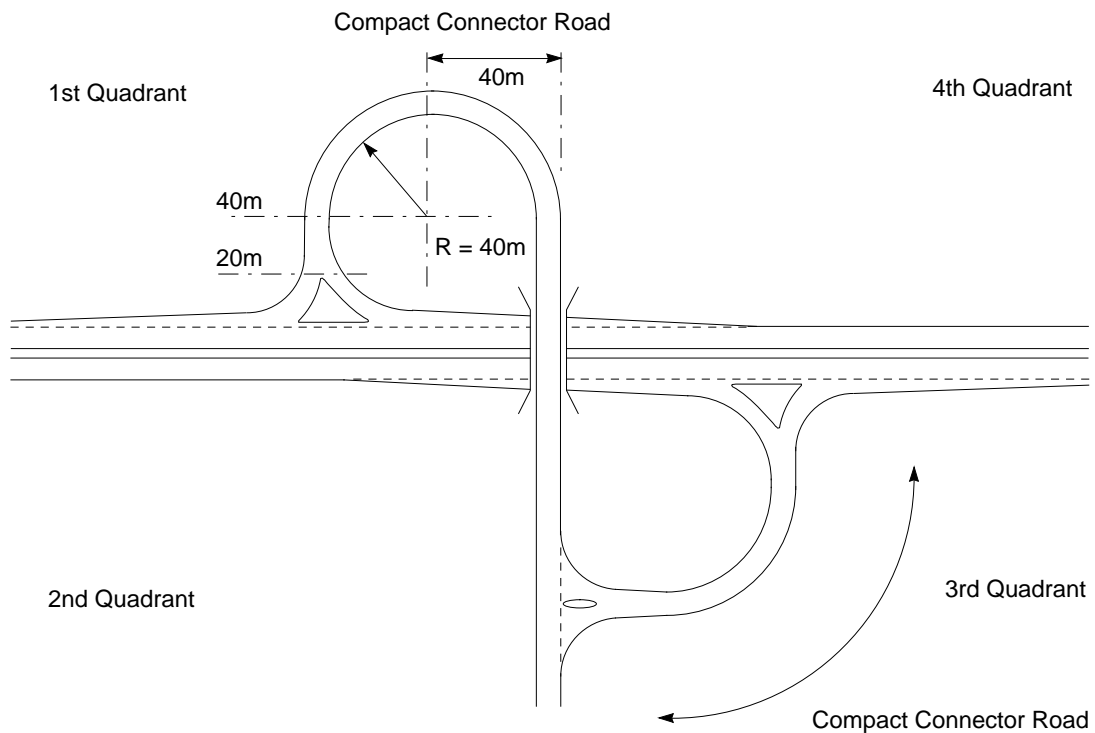

Figure 7/4 Compact Grade Separation for 3 Arm Junction, Showing Merge and Diverge Tapers

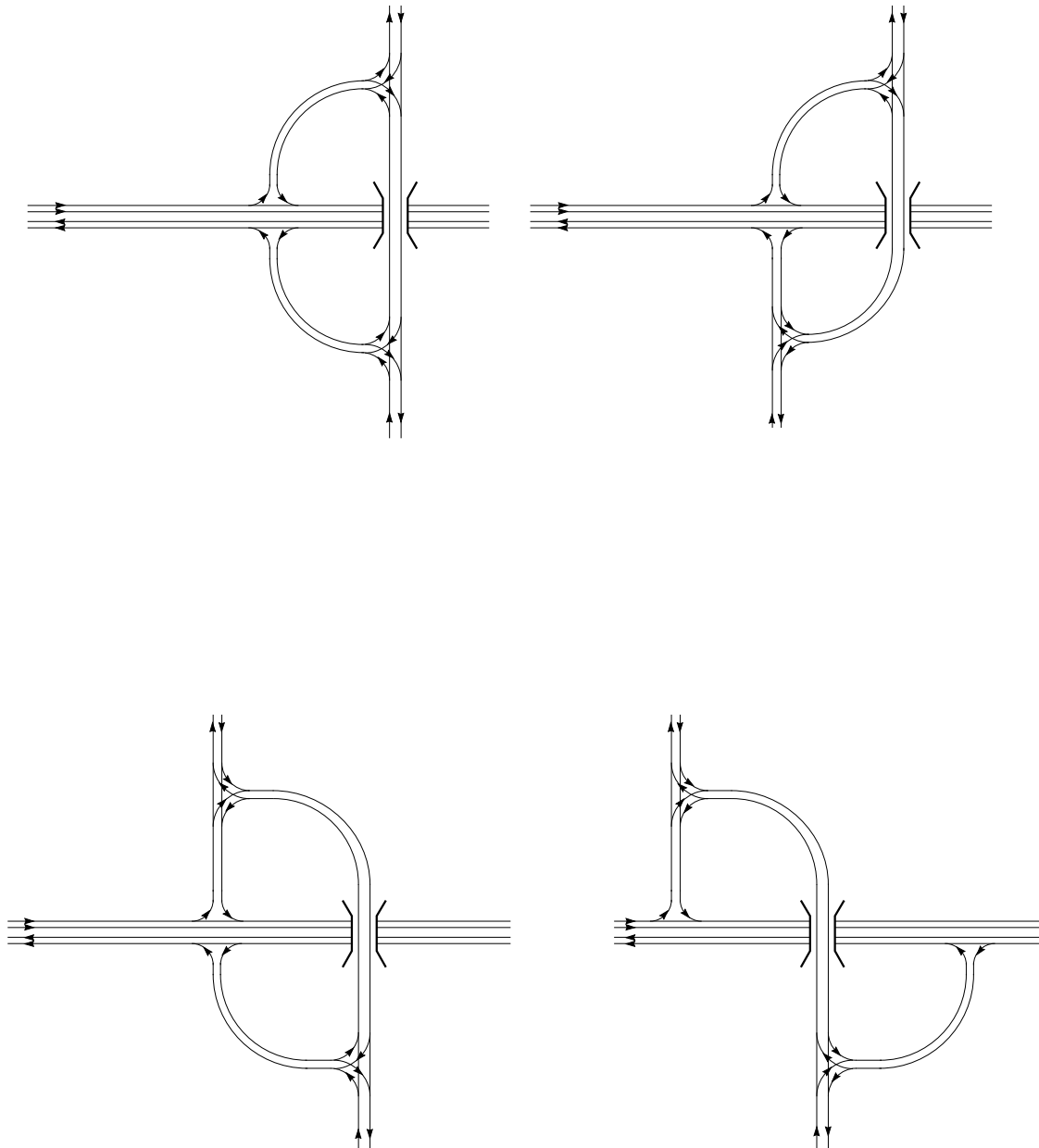

Figure 7/5 Schematic Examples of 4 Arm Compact Grade Separation on Dual Carriageway

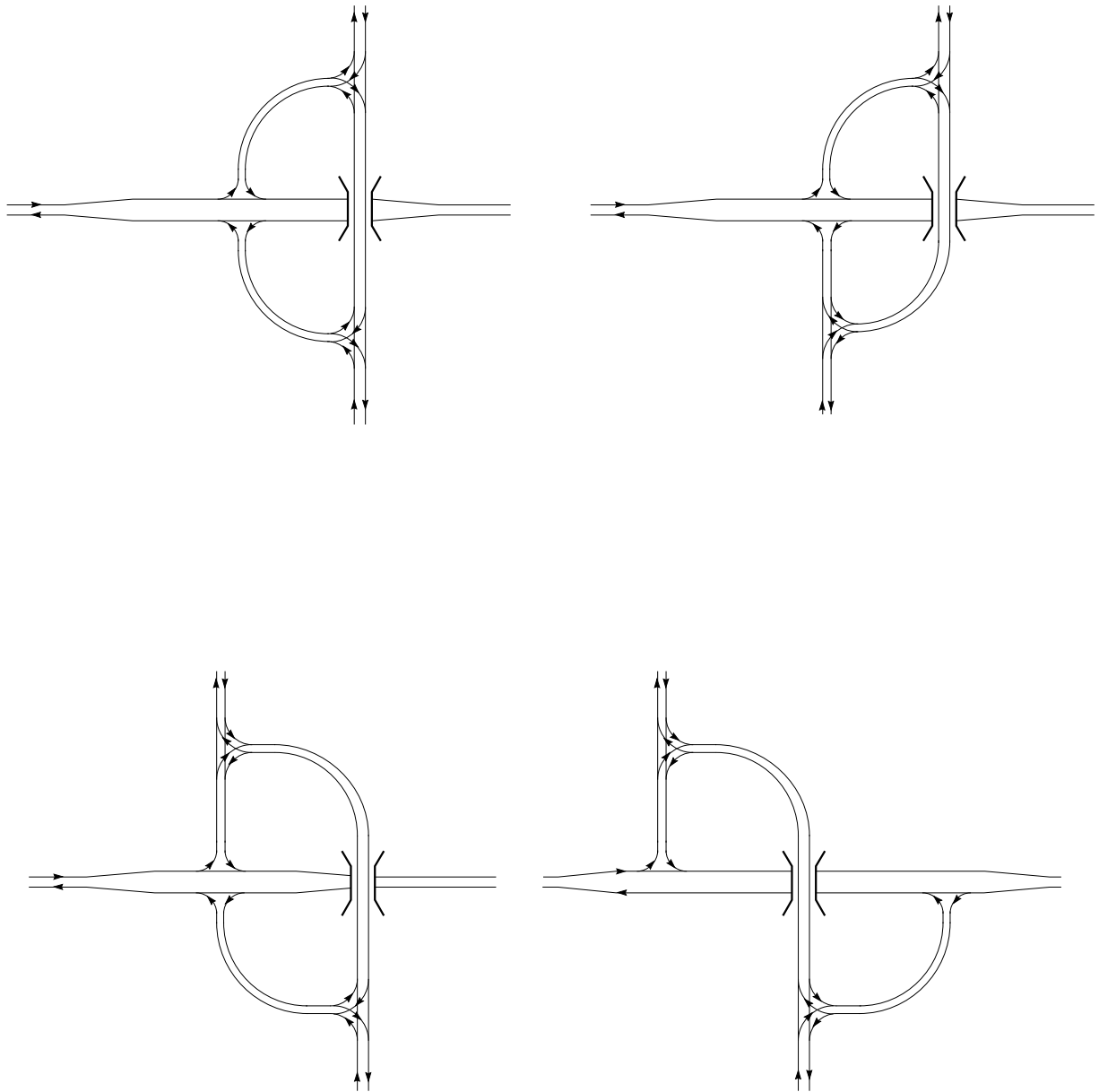

Figure 7/6 Schematic Examples of 4 Arm Compact Grade Separation Single Carriageway

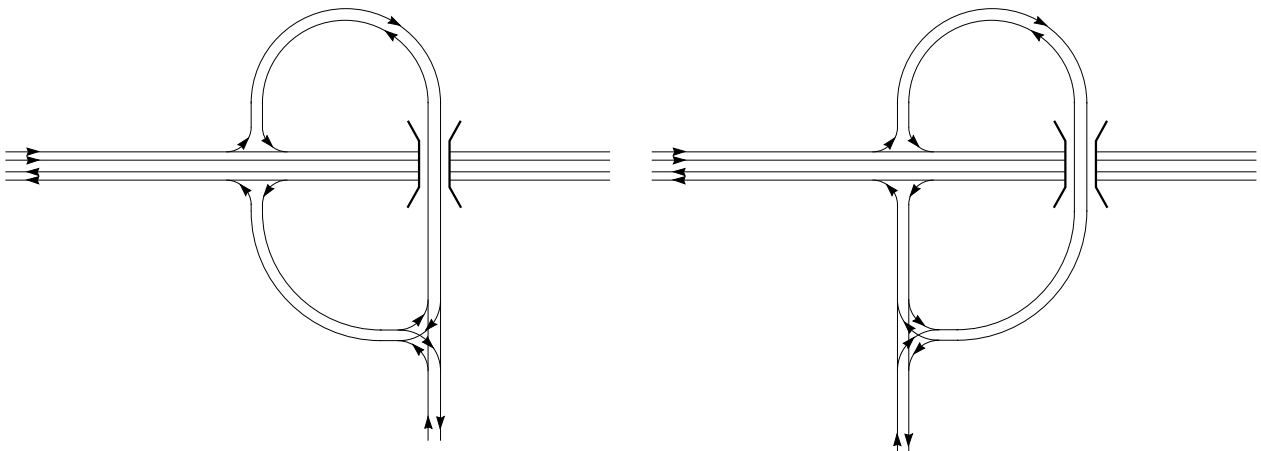

Figure 7/7 Schematic Examples of 3 Arm Compact Grade Separation on Dual Carriageways

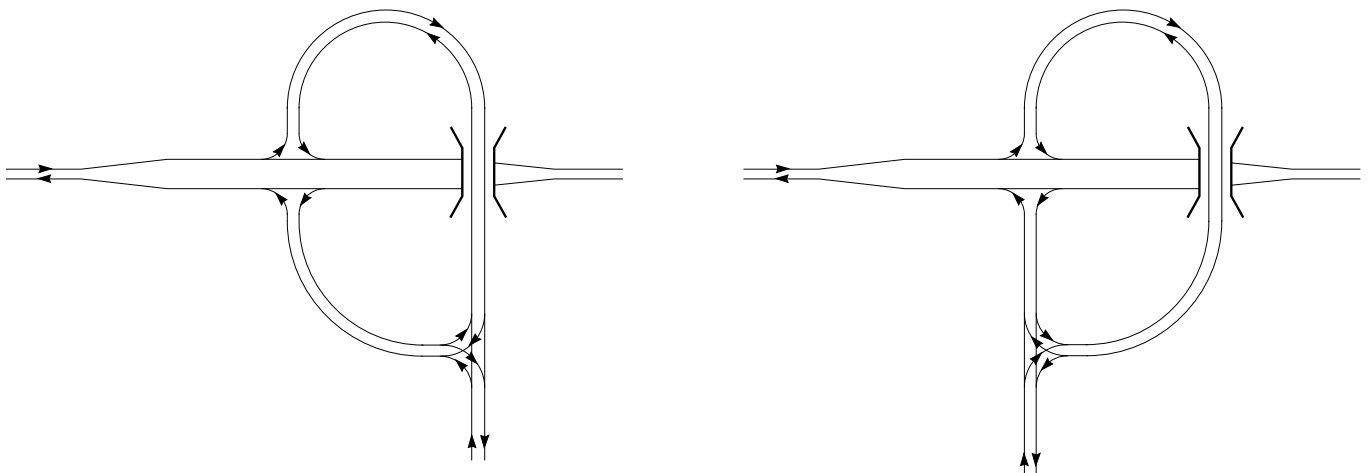
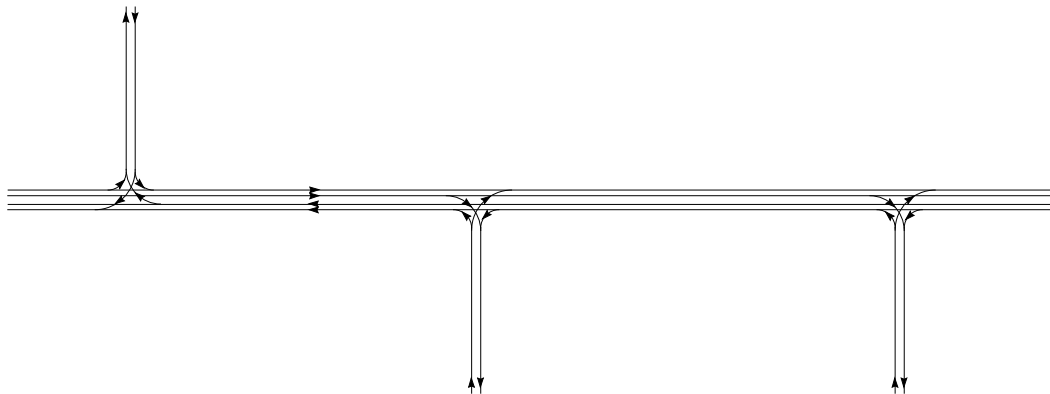
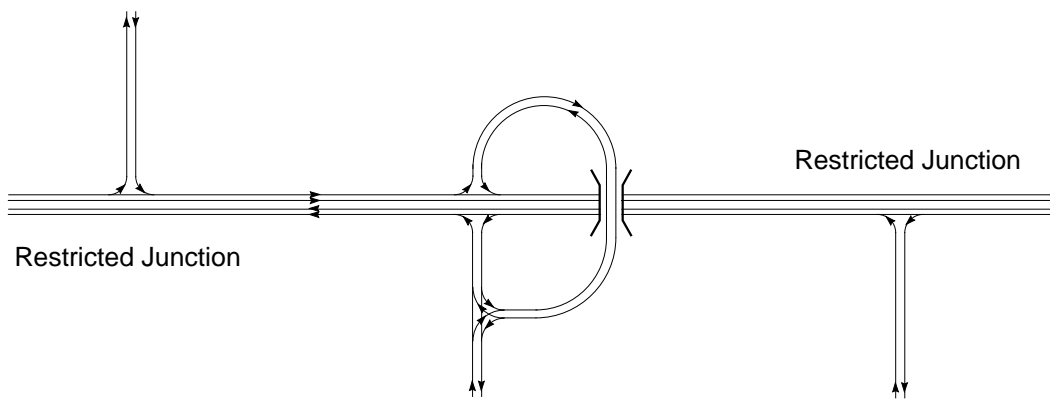

Figure 7/8 Schematic Examples of 3 Arm Compact Grade Separation on Single Carriageways



Existing Layout indicating 3 arm junctions



Proposed Layout indicating Compact Grade Separation and Restricted Junctions

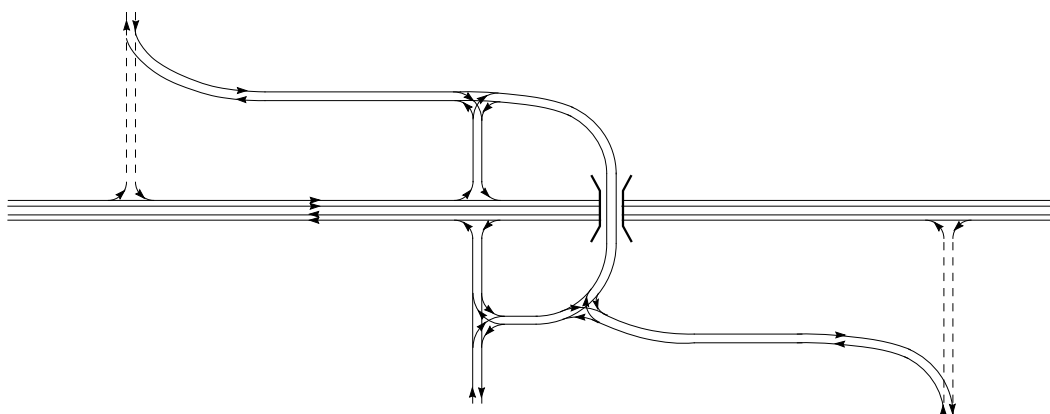

Proposed Layout indicating Compact Grade Separation and Total Diversion of Minor Side Roads and/or Accommodation Roads

Figure 7/9 Schematic Example of Compact Grade Separation and Restricted Junctions

8. REFERENCES

1. **DESIGN MANUAL FOR ROADS AND BRIDGES** : HMSO
 - a. **TD 22 (DMRB 6.2.1)** - Layout of Grade Separated Junctions
 - b. **TA 20 (DMRB 6.2)** - The Layout of Major/Minor Junctions
 - c. **TA 30 (DMRB 5.1)** - Choice between options for Trunk Road Schemes
 - d. **TD 44 (DMRB 6.2)** - {Title to be inserted here}
 - e. **TD 9 (DMRB 6.1.1)** - Highway Link Design
 - f. **TA 57 (DMRB 6.3)** - Roadside Features
 - g. **Environmental Design (DMRB 10)** - The Good Roads Guides
2. **MANUAL OF CONTRACT DOCUMENTS FOR HIGHWAY WORKS** : HMSO
 - a. **Highway Construction Details (MCHW 3.1)** -Carriageway and Other Details
3. **BRITISH STANDARDS**
 - a. **BS6100 Subsection 2.4.1 1990** - The British Standard Glossary of Building and Civil Engineering Section 2.4 Highway and Railway Engineering; Subsection 2.4.1 Highway Engineering; British Standards Institution 1990 (UDC 001.4:(624+69))
4. **TRAFFIC APPRAISAL**
 - a. **Traffic Appraisal Manual** - (TAM) 1: DoT: 1982
 - b. **Scottish Traffic Appraisal Manual** - (STEAM): SDD:1986
 - c. **TRRL Supplementary Report 582**- The Traffic Capacity of Major/Minor Priority Junctions - Transport and Road Research Laboratory: 1980
5. **ACCIDENT ASSESSMENT**
 - a. **Road Accidents in Great Britain (The Casualty Report)**: HMSO: Annually
 - b. **STATS19 - DoT database of Road Accidents**: DoT: Annual
6. **ECONOMIC ASSESSMENT**
 - a. **COBA - Cost Benefit Analysis - COBA 9 Manual**: DoT: 1981
 - b. **NESA - Network Evaluation from Surveys and Assignments - NESA**: SDD: 1986
 - c. **ROADS 502** - Assessment of schemes: DoT: 1989
7. **MISCELLANEOUS**
 - a. **SI 1981 No 859** - The Traffic Signs Regulations and General directions 1981: HMSO 1981, **SI 1982 No 1879** - The Traffic Signs [Amendment] Regulations 1982 and **SI 1982 No 1880** - The Traffic Signs General [Amendment] Direction 1982: HMSO : 1982 - SR 1979 No 386 Traffic Signs Regulations (Northern Ireland)
 - b. **Local Transport Note (1/86)** - Cyclists at Road Crossings and Junctions - HMSO
 - c. **Traffic Advisory Leaflet (1/88)** - Provision for Cyclists at Grade Separated Junctions - HMSO
 - d. **Cycling Advice Note (1/89)** - Providing for the Cyclist - SDD
 - e. **Cycling Advice Note (1/90)** - Making Way for Cyclists - SDD
 - f. **The Traffic Signs Manual** - Chapters 1, 3, 4, 5 and 14 - HMSO

9. ENQUIRIES

All technical enquiries or comments on this document should be sent in writing as appropriate to:-

The Civil Engineering and Environmental Policy Director
Highways Agency
St Christopher House
Southwark Street
London
SE1 0TE

T. A. ROCHESTER
Civil Engineering
and Environmental Policy Director

The Deputy Chief Engineer
The Scottish Office Industry Department
Roads Directorate
New St Andrew's House
Edinburgh
EH1 3TG

J. INNES
Deputy Chief Engineer

The Director of Highways
Welsh Office
Y Swyddfa Gymreig
Government Buildings
Ty Glas Road
Llanishen
Cardiff
CF4 5PL

K. J. THOMAS
Director of Highways

Chief Engineer - Roads Service
Department of the Environment
for Northern Ireland
Road Service Headquarters
Clarence Court
10 - 18 Adelaide Street
Belfast
BT2 8GB

W. J. McCOUBREY
Chief Engineer - Roads Service