VOLUME 6 ROAD GEOMETRY
SECTION 3 HIGHWAY FEATURES

PART 3

TA 69/96

**THE LOCATION AND LAYOUT OF
LAY-BYS**

SUMMARY

This Advice Note gives advice on the siting and design of lay-bys on all-purpose trunk roads.

INSTRUCTIONS FOR USE

1. Mark TA 57/87 Volume 6 Section 3, to show that Chapter 2 “lay-bys” is superseded by this Advice Note.
2. Insert TA 69/96 into Volume 6 Section 3 Part 3.
3. Archive this sheet as appropriate.

Note: A quarterly Index with a full set of Volume Contents Pages is available separately from HMSO.



THE HIGHWAYS AGENCY



THE SCOTTISH OFFICE DEVELOPMENT DEPARTMENT



**THE WELSH OFFICE
Y SWYDDFA GYMREIG**



**THE DEPARTMENT OF THE ENVIRONMENT FOR
NORTHERN IRELAND**

The Location and Layout of Lay-Bys

Summary: This document gives advice on the siting and design of lay-bys on all-purpose trunk roads.

REGISTRATION OF AMENDMENTS

Amend No	Page No	Signature & Date of incorporation of amendments	Amend No	Page No	Signature & Date of incorporation of amendments

REGISTRATION OF AMENDMENTS

Amend No	Page No	Signature & Date of incorporation of amendments	Amend No	Page No	Signature & Date of incorporation of amendments

VOLUME 6 ROAD GEOMETRY
SECTION 3 HIGHWAY FEATURES

PART 3

TA 69/96

**THE LOCATION AND LAYOUT OF
LAY-BYS**

Contents

Chapter

1. Introduction
2. General Principles
3. Siting and Frequency
4. Layout Design
5. References
6. Enquiries

1. INTRODUCTION

General

1.1 Advice Note TA 57/87 “Roadside features” (DMRB 6.3) included guidance on the preferred locations and layout of lay-bys for all-purpose trunk roads. The document introduced a physical separation island between the lay-by and the through carriageway to improve safety.

1.2 Since TA 57 was issued, the safety and operation of a number of lay-bys built to that document have been monitored, together with alternative layout arrangements. The monitoring confirmed that lay-bys are an important facility for road users, but that the location of a lay-by needs to be chosen carefully for the facility to be used in the most safe and effective manner. The results of the monitoring have been incorporated into this new Advice Note.

1.3 The main changes from TA 57 are: The separation island is more visible and clearly marked, alternative layouts for the exit from the lay-by have been included, and lay-bys for emergency use have been added.

Scope

1.4 This Advice Note is applicable to all-purpose trunk roads. It supersedes Chapter 2 of TA 57/87 (DMRB 6.3) and that Chapter is hereby withdrawn.

Implementation

1.5 This Advice Note should be used forthwith on all schemes for the management, improvement and maintenance of trunk roads currently being prepared, provided that, in the opinion of the Overseeing Organisation, this would not result in significant additional expense or delay progress. Design Organisations should confirm its application to particular schemes with the Overseeing Organisation.

2. GENERAL PRINCIPLES

2.1 Lay-bys are convenient places for drivers to stop. They help to improve safety by reducing the number of accidents involving stopped vehicles. Lay-bys serve as halting places on long journeys, for the enjoyment of places of scenic interest, for safe parking whilst making telephone calls (normal lay-bys), for broken down vehicles (emergency lay-bys), and for bus stops (bus lay-bys). For some of these purposes, rest areas are considered safer and superior provision. The advice in this section is primarily for rural roads but some of the principles may be beneficially applied to urban areas. Where lay-bys are properly provided experience indicates that they are well used.

2.2 The national statistics for personal injury accidents on rural roads covering the years 1986 - 1992 show that 4 to 5% involve stationary vehicles. This includes accidents involving parked vehicles, and vehicles passing stationary vehicles. The average figure was 2551 accidents per year, with a severity ratio of 25%. These figures emphasise the value of lay-bys in reducing the incidence due to stationary vehicles on the carriageway.

2.3 Emergency lay-bys can be installed on roads where stopping for purposes other than a vehicle breakdown or other emergency is not desirable either for reasons of safety or operational efficiency.

3. SITING AND FREQUENCY

Siting

3.1 There are a number of factors that should be taken into account when considering the siting of a lay-by. Table 3.1 gives guidance. Siting affects the safety and operation of the lay-by and the landtake requirements for the scheme and consequently is best considered at an early stage in the design process to

reach a balanced solution. Siting of lay-bys should particularly be avoided on the inside of curves and at locations near junctions and signing.

FACTOR	AVOID	PREFERRED	REASON
Vertical and horizontal alignment of carriageway in vicinity of lay-by.	<ul style="list-style-type: none"> • Inside of curves. • Sharp crests. • Bridges and other structures. • Bottom of gradients where visibility is not adequate 	Forward visibility standards are contained in TD 9/93 (DMRB 6.1.1). Visibility on exit should conform to TD 42/95 (DMRB 6.2.6)	<ul style="list-style-type: none"> • To ensure adequate visibility for traffic entering and leaving the lay-by and for the traffic on the mainline if the lay-by is in the line of visibility.
Location of other lay-bys on single carriageways.	<ul style="list-style-type: none"> • Single lay-bys on one side of the road only. • Locating lay-bys directly opposite one another 	<ul style="list-style-type: none"> • Lay-bys (one each side) wherever possible. • Configured to left-right stagger and at least 150m apart, (left side lay-by first). • Where telephones are provided 	<ul style="list-style-type: none"> • To prevent right turns into the lay-by. • To prevent U turns across the carriageway.
Environment.	Houses, woods and adjacent ground cover.	Open aspect.	<ul style="list-style-type: none"> • To avoid noise intrusion. • To avoid visual intrusion. • To discourage pollution and soiling. • For security and to avoid nuisance to households.
On-line improvement.	Use of redundant highway as lay-by without reference to design standards.	Use of standard layouts.	<ul style="list-style-type: none"> • To ensure basic safety requirements of lay-bys • To avoid misuse.
Proximity of junctions.	Location after any Advance Direction Signing or within countdown signs for exits off main carriageway or an entry from another road.	Location clear of adjacent junctions and signing.	To avoid confusion of lay-by with junction exit and entry particularly at night.
Facilities provided in a lay-by.	<ul style="list-style-type: none"> • Provision of infrequently used facilities • Under provision of services can lead to soiling, litter, unwanted trading. 	<ul style="list-style-type: none"> • Carefully determine need for lay-by. • Consider provision of toilets or rest area in liaison with local authorities. 	<ul style="list-style-type: none"> • Can encourage vandalism and undesirable behaviour. • Where route is consistently through rural areas facilities may be required.
Misuse of lay-by.	<ul style="list-style-type: none"> • Location near train or bus interchange. • Use as lorry park. 	Consideration of local parking facilities.	<ul style="list-style-type: none"> • May encourage long stay parking and use as park and ride facility. • May prevent or discourage appropriate use.
Lay-bys for emergency use.	Non-emergency use.	Provide conventional lay-by where demand exists.	To ensure emergency use facility is maintained.

Table 3.1: Siting Considerations

Frequency

3.2 Lay-bys are desirable for new all-purpose trunk road schemes in each direction. The desirable frequency of conventional and emergency lay-bys should be:

- (a) On all dual carriageway roads: 2.5 km;
- (b) On single carriageway roads frequency depends on traffic flows:
 - (i) traffic flow greater than 8000 vehicles AADT: 2-5 km;
 - (ii) traffic flow 2500-8000 vehicles AADT: 5-8 km;
 - (iii) traffic flow 1200-2500 vehicles AADT: 8-12 km.

Traffic flows given above are those expected in the opening year and are given as a guide. Should the traffic flows significantly change, they should be taken into account to derive the opening year flows.

The spacing of lay-bys may be changed to coincide with Emergency Telephone locations.

4. LAYOUT DESIGN

Safety Considerations

4.1 Accident statistics from the 1980's suggest that accidents at lay-bys represent about 0.8% of all injury accidents on rural roads in Great Britain. An annual average of 432 injury accidents on rural all-purpose roads were recorded between 1986 - 1992 involving vehicles entering, leaving or parked at lay-bys (Road Accidents in GB). This included vehicles hitting pedestrians at lay-bys. The overall severity rate of the accidents was 25%. These figures emphasise the need for lay-bys to be placed in selected locations with appropriate design and choice of layout details.

Lay-By Types

4.2 Five distinct alternative layout types are recommended. Geometric details are given in Figure 1 and 1a and typical applications are described in Table 4.1.

4.4 The Type A modified lay-by is similar to Type A, but has an additional merge taper. It is only for use on dual carriageways in situations where the merge taper will assist vehicles to rejoin main line flows that are both high volume and fast moving.

4.5 Lay-by Type C is the standard bus bay with a full width parking area 12 metres long for use by buses up to 11 metres in length which is the maximum length of buses in frequent use. However, longer buses may become more popular. For this reason longer parking areas may be provided and consultation with operating authorities would be helpful when considering this option.

4.6 Bus lay-bys should be clearly defined by carriageway markings to prevent other vehicles stopping on them. Use of markings to diagram 1025.2 and 1025.3 as detailed in the Traffic Signs Regulations and General Directions 1994 are appropriate. A guardrail may be erected at suitable locations in the vicinity of the bus lay-bys to discourage pedestrians crossing at points which could cause accidents.

Carriageway Type	>8000 AADT vehicles	<8000 AADT vehicles	Bus use only	Emergency use
Single	A	A or B	C	Emergency Lay-by
Dual	A or A Modified	A or B	C	Emergency Lay-by

Table 4.1: Lay-by Type and Application

4.3 The preferred layout is the Type A lay-by for both single and dual carriageway situations where physical separation from the carriageway is desirable. This is the case where traffic speeds are high. Lay-by Type B may be used where traffic speeds are generally lower and traffic volumes lighter.

4.7 The emergency lay-by is designed to the same geometric standards as Type B with additional markings and signs as described in [Paras 4.24 and 4.25].

Capacity

4.8 If the number of vehicles wishing to use the lay-by frequently exceeds the stopping capacity within the lay-by there can be operational problems and increased accident risk. Common problems caused by lack of capacity are; parking on tapers or outside of lay-by; collisions within the lay-by; over-running of grass verges, footway and segregation island.

4.9 A range of widths for the parking section of the type A lay-by is given. Where a high proportion of heavy goods vehicles are expected the wider sections are most appropriate. The stopping bay length should be based on an estimation of demand within the length limits shown. Estimation of demand will be affected by local factors including proximity to major junctions and other facilities provided.

Signing

4.10 With lay-bys located at regular intervals, drivers have a choice whether to stop at a specific lay-by or not. Good advance signing assists in this decision and helps to avoid sudden deceleration on the approach to the lay-by, with attempts to enter the lay-by at too high a speed. Advanced signs to diagram 801 of the Traffic Signs Regulations and General Directions 1994 should be used and distance sub-plates are advised, particularly where there is a regular spacing of lay-bys. Carriageway markings should have reflective studs to Traffic Sign Manual, Chapter 5: Road Markings, 1985. Refer to SHW and NFG 1100 series for different lay-by surfacing.

Segregation Island

4.11 The segregation island on a Type A lay-by is a safety feature that separates main line traffic from parked vehicles, restricts access to and egress from designated areas, and by restricting through width encourages drivers to slow down in good time on entering the parking area. However, accidents can occur when the central island is not sufficiently conspicuous to both vehicles on the main carriageway and those entering the lay-by. For this reason standard

black and white reflector posts placed at 1.2 to 1.5 metre centres along the island are particularly useful.

4.12 The segregating island should be raised and solid construction is preferable to grass for ease of maintenance. This allows for occasional over-riding by long vehicles and avoids possible obstruction of visibility by long grass. Consideration may also be given to using a different surface colour for the infill area.

4.13 The type of kerbing used for the segregation island should help to minimise the effects of vehicles over-running during snow or bad visibility. In situations where the lay-by is approached from a curve, consideration should be given to the use of marking by reflectorised paint for the nosing of the dividing island rather than initial solid construction.

4.14 For kerbed roads without a 1 metre hardstrip the segregation island should be no closer than 300 mm from the outside of the carriageway edge.

Entries and Exits

4.15 A high proportion of accidents occurring at lay-bys are associated with misuse of the entry and exit points. Incidents include; mistaken entry into the lay-by, using the lay-by for U-turns, and two-way operation within the lay-by. Careful siting and design can assist in deterring such manoeuvres. Exit only / Entry only signs can be effective.

4.16 In the case of Type A lay-bys, the entry point is made obvious by a continuous edge of carriageway marking across the lay-by entry, extended hatching and a conspicuous segregation island. Traffic leaving the lay-by should give way to traffic on the main carriageway, with priority clarified by give-way markings on the exit incorporating a triangular approach marking. Entry through the designated exit is dissuaded by these markings and a sign showing “No-entry” .

4.17 The type A modified lay-by provides an exit taper, allowing traffic leaving the lay-by to merge with main line traffic. Merge length (and diverge length) is dependent upon design speed, see TD 41/95 (DMRB 6.2) “Providing For Access”, for guidance. For consistency it may be desirable to choose exit types that are similar to merges at adjacent junctions.

Footway and Kerbing

4.18 A footway 2 metre wide, adjacent to the lay-by, is desirable to encourage parking adjacent to the kerb edge and to provide a surfaced area for vehicle occupants to walk on. The footway should be separated from the vehicle parking area by a raised kerb to improve the safety of those on foot.

4.19 Raised kerbing is not needed on the remainder of the lay-by, but it is often used to facilitate drainage, to make the location of the edge of the surfacing clearer, and to dissuade parking on the verge adjacent to the tapers. Raised kerbs should not encroach within the 1.0 metre hard strip of the main carriageway.

Lighting

4.20 When the road has street lighting the lay-by should be illuminated to the same standard as the carriageway. Where no lighting exists a road marking strip 100 mm wide may be laid at the back of the parking bay area to facilitate identification. Lighting columns should not be located on the segregation island.

Facilities for Users

4.21 Consideration should be given to inviting the telephone companies to install public telephone kiosks in lay-bys on the approaches to by-passed towns and villages, and in remote locations where no alternative facilities exist. In view of the minimal cost of ducts, they should be laid at the time of construction of the lay-by in order to avoid costly works at a later date if a decision is subsequently made to install telephones. Where telephones are provided, they should be installed in lay-bys on both sides of the road so that drivers do not need to cross the road to reach a telephone.

4.22 Emergency telephones connected to the police control centre may be considered in certain locations, and advice may be obtained from the Overseeing Organisation. Emergency telephones can be introduced in any lay-by without it being designated for emergency use only. Alternatively, motoring organisations or telephone companies may be invited to install emergency telephones.

4.23 Lay-bys are not intended to accommodate roadside trading. The presence of roadside trading can cause congestion, parking outside of the lay-by, unsafe manoeuvres and environmental damage. However, where mobile traders, snack bars, flower stalls etc. are safely located, and are not an environmental nuisance, they are sometimes tolerated by highway authorities, although where such facilities cause a safety hazard, various powers exist to remove them. The presence of mobile traders may indicate the need for a rest area.

Emergency Lay-bys

4.24 In situations where there is a possibility of long term parking denying space for occasional emergency stops or breakdown stops, or where there is strong opposition to the construction of a Type A or B lay-by for public use, consideration may be given to the construction of a lay-by for emergency use only.

4.25 Emergency lay-bys should incorporate an emergency telephone and be signed according to diagram 2714 and 2715 of the Traffic Signs Regulations and General Directions, 1994. A sign to diagram 2713.1 should be erected at least 800 metres before the entry to give advanced warning to drivers. Carriageway markings should have reflective studs to Traffic Sign Manual, Chapter 5: Road Markings; 1985.

4.26 In order to exclude traffic other than that involved in an emergency it is necessary to promote a Traffic Regulation Order. A regulatory sign stating, "No Stopping Except in Emergency" supported by double yellow lines to diagram 1018.1 along the back edge of the lay-by and the tapers indicates to drivers the restrictions on usage.

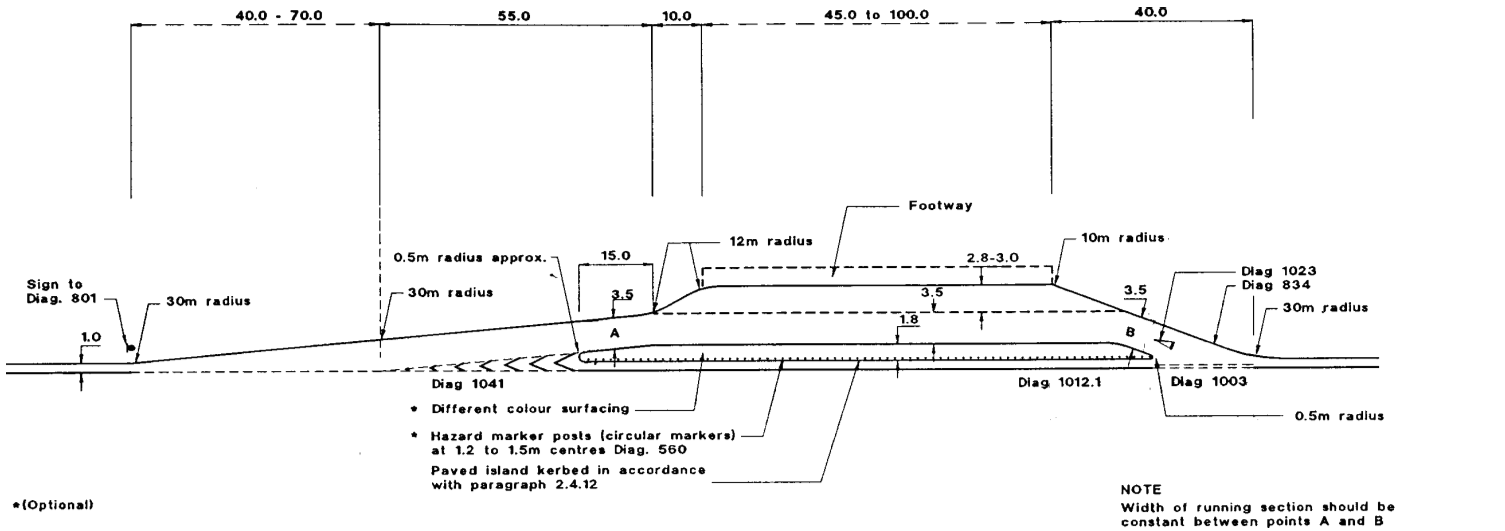

Type A

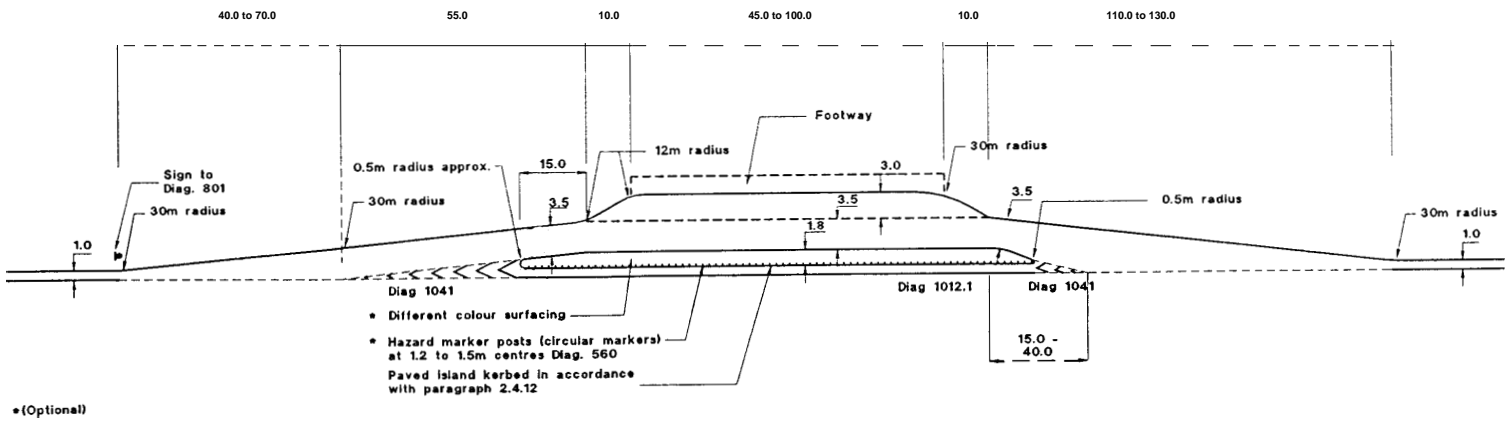

Type A - Modified

Figure 1 - Geometric Layout of 'Lay-bys'

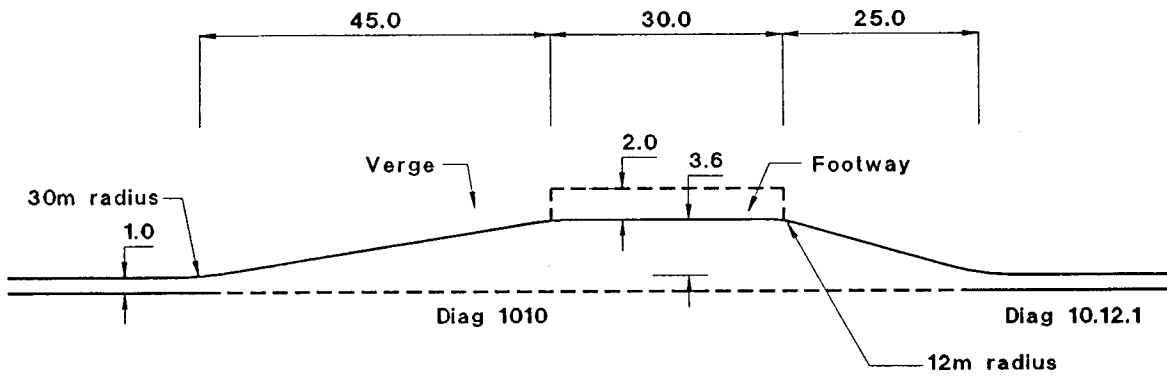

Type B

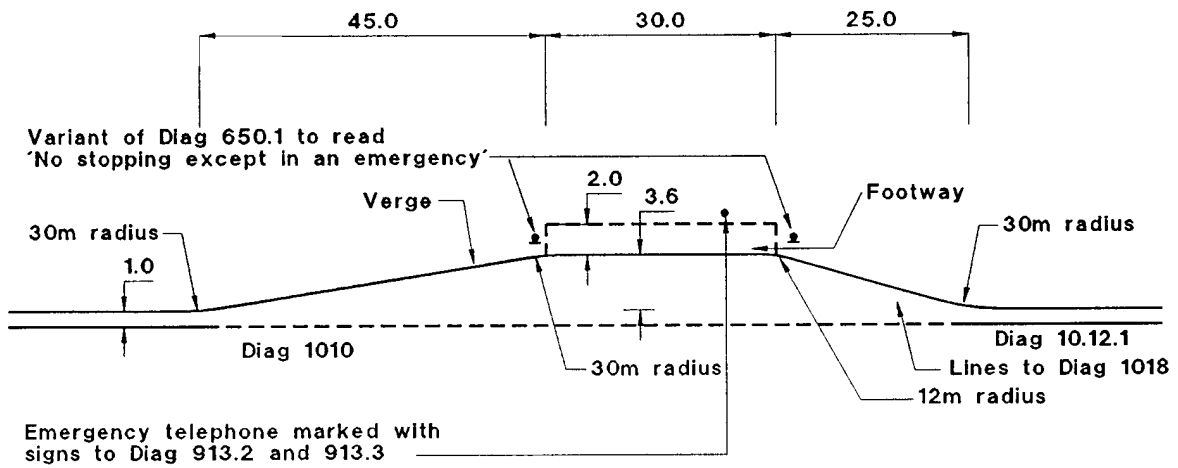

Emergency Lay-By

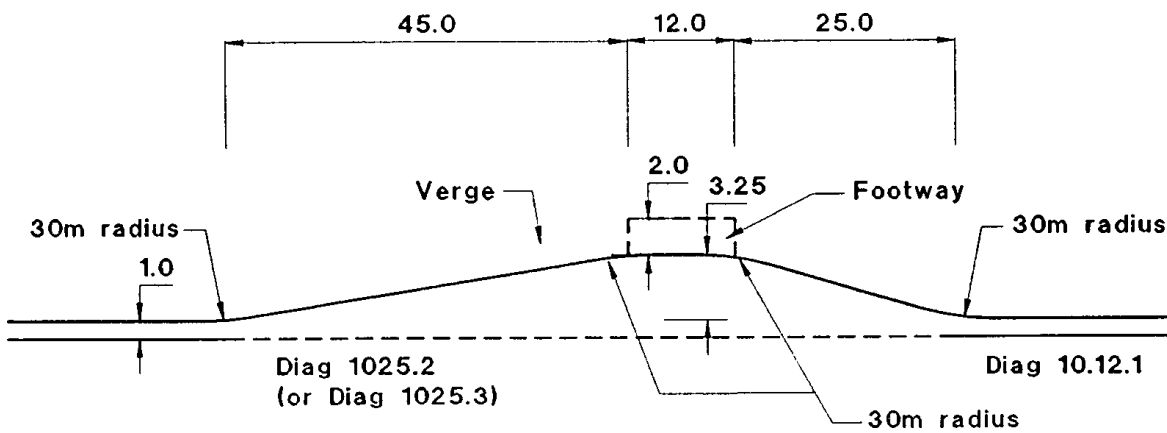

Bus Lay-By Type C

Figure 1a - Geometric Layout of 'Lay-bys'

5. REFERENCES

1. Traffic Signs Regulations and General Directions 1994.
2. Traffic Signs Manual, 1986 (Chapter 4, Warning Signs).
3. Traffic Signs Manual, 1985 (Chapter 5, Road Markings).