

# SIGNS FOR CYCLE FACILITIES

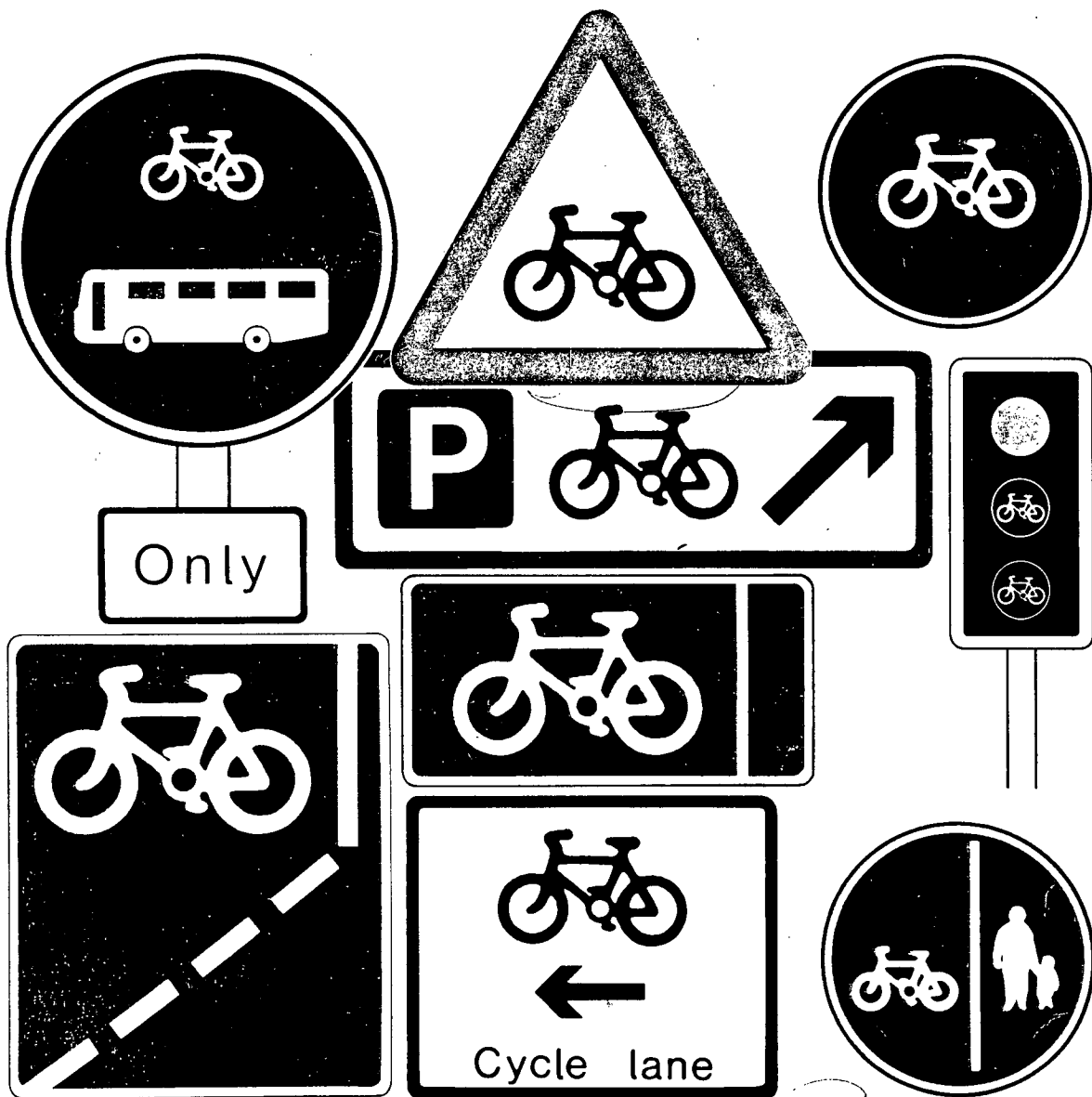

LOCAL TRANSPORT NOTE 2/87

Department of Transport  
The Welsh Office

# Local Transport Note 2/87

## Signs for Cycle Facilities

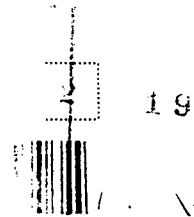



15960387

Return Date:

16 MAR 77 11 15

Request Ref. No.  
MP30224Y

If no other library indicated please return loan to:-  
The British Library Document Supply Centre, Boston Spa,  
Wetherby, West Yorkshire, LS23 7BQ



© *Crown Copyright 1987*  
*First published 1987*

ISBN 0 11 550834 1

# Department of Transport/The Welsh Office

## Local Transport Note: 2/87

<b>TITLE</b>  <b>SIGNS FOR CYCLE FACILITIES</b>  Department of Transport. The Welsh Office.
<b>ISSUING DIVISION</b> Traffic Policy Division  <b>CONTACT POINT</b> Department of Transport: Mr B Poole, Traffic Policy Division, 2, Marsham Street, London SW1P 3EB. Telephone 01-212 7945
<b>ENQUIRIES</b>  All enquiries on the general applicability of this Advice Note should be directed, in England, to the appropriate Regional Cycling Officer of the Department of Transport or, in Wales, to the Transport and Highways Group of the Welsh Office, Government Buildings, Ty Glas Road, Cardiff.  Enquiries which fall outside the scope of the above may be sent in writing to Traffic Signs Branch, Administration of Road Construction Division, 2 Monck Street, London SW1P 3EB, Telephone 01-212 4110.
<b>ABSTRACT</b>  This note updates the signing methods available for cycle facilities set out in LTN 1/83. It illustrates the prescribed and non-prescribed signs that are now available and gives guidance on their use.
<b>PUBLICATIONS SUPERSEDED</b>  Local Transport Note 1/83.

# CONTENTS

	Paras.	Page
1 INTRODUCTION	1.1 - 1.3	5
2 STATUS OF SIGNS FOR CYCLE FACILITIES	2.1, 2.2	5
3 ADVISORY CYCLE ROUTES	3.1, 3.2	5
4 ROAD CLOSURES	4.1, 4.2	5
5 MANDATORY CYCLE LANES	5.1 - 5.7	6
6 ADVISORY CYCLE LANES	6.1	9
7 STREETS WHERE MOTOR VEHICLE USE IS RESTRICTED	7.1, 7.2	9
8 CYCLE USE OF BUS LANES	8.1	10
9 CYCLE TRACKS	9.1 - 9.4	11
10 SHARED ROUTES	10.1 - 10.3	13
11 DIRECTION SIGNS	11.1	14
12 ADVISORY CROSSINGS OF MINOR ROADS	12.1, 12.2	15
13 MAJOR ROAD CROSSINGS	13.1, 13.2	16
14 PARKING PLACES	14.1	16
15 TACTILE SIGNS	15.1	17
16 MOPEDS	16.1	18
<b>APPENDIX</b>		
<b>REFERENCES</b>	-	19
<b>ANNEX A – LIST OF SIGNS AND ROAD MARKINGS FOR CYCLE FACILITIES</b>		20

## 1 Introduction

1.1 Local Transport Notes 1/86 (Ref.5) "Cyclists at Road Crossings and Junctions" and 2/86 (Ref.6) "Shared Use by Cyclists and Pedestrians" replaced parts of Local Transport Note 1/78 (Ref.4) "Ways of Helping Cyclists in Built-up Areas". LTN 1/86 also superseded paragraph 28 of Appendix 1 to Local Transport Note 1/83 "Signs for Cycle Facilities".

1.2 The following detailed guidance replaces the remainder of the material in Appendix 1 of LTN 1/83. It contains up to date advice which takes account of changes stemming from legislation, principally the Cycle Tracks Act 1984.

1.3 The extant portions of LTN 1/78 will be revised and incorporated in a further Local Transport Note on cycling, which will cover the handling of statutory and planning processes.

## 2 Status of Signs for Cycle Facilities

2.1 The signs referred to within the text are those prescribed in regulations and directions made in 1981 (Ref.1) or 1982 (Ref.2) or are non-prescribed signs requiring Departmental authorisation before use. The signs within each category are listed in Annex A.

2.2 It is important that the appropriate Regional Office of the Department should be consulted at an early stage in the development of any cycle scheme where non-prescribed signs are to be used, and approval in principle sought before the scheme is finalised. Non-prescribed signs must not be erected until formal authorisation has been received. In Wales equivalent reference should be made to the Welsh Office.

## 3 Advisory Cycle Routes

3.1 The conventional method of indicating an advisory cycle route has been to use the prescribed sign to diagram 815 displayed where necessary to indicate the route to be followed. It should be borne in mind that where a comprehensive advisory route is provided, this method may result in a large number of upright signs having to be provided which would be costly, unsightly and possibly unwelcome in residential or amenity areas. Therefore the normal method now used is to provide cycle route direction signs (diagrams 732.4 and 732.5, see para. 11.1) only at junctions, for advisory routes on low flow roads.

815 Route recommended for pedal cycles.

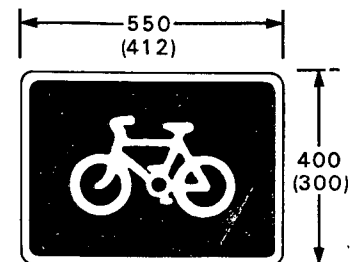

3.2 'Ghost' islands using road markings to diagrams 1040 or 1040.1, as well as islands with internally lit bollards, may be provided at junctions to assist right turning cycle movements where appropriate.

## 4 Road Closures

4.1 Where a road is to be physically closed to vehicular traffic, it may be desirable to retain access for cyclists. In such cases, the prescribed 'no through road' signs to diagrams 816, 816.1 or 817 placed in advance of the closure

should be supplemented by the 'except cycles' plate to diagram 817.1 (see para. 7.2). The cycle gap at the point of closure should be indicated by signs to diagram 625 (see para. 9.1) displayed in conjunction with the cycle symbol marking to diagram 1057 (see para. 5.1).

4.2 Where a road is closed temporarily, for example for road works, and it is possible to provide a special diversion route *for cyclists*, temporary worded signs with a black legend on a yellow background may be erected in accordance with the provisions of Regulation 27 of the Traffic Signs Regulations and General Directions 1981 (Ref.1) as amended by the Traffic Signs (Amendment) Regulations 1982 (Ref.2), without special authorisation.

## 5 Mandatory Cycle Lanes

5.1 Mandatory cycle lanes should be indicated in much the same way as bus lanes. They should be bounded by a 150mm solid white line (diagram 1049) broken at each side road junction and for the length of any bus stop (markings diagrams 1025 and 1025.1) incorporated within the lane. The beginning of the cycle lane should be delineated by a 150mm wide inclined broken white line (diagram 1009). Cycle symbol markings (diagram 1057) should be placed at the beginning of, and after every break in, the cycle lane, as well as at suitable intervals on long uninterrupted stretches of cycle lane. The termination point should be indicated by an "END" carriageway marking (diagram 1058) placed immediately beyond the cycle symbol (diagram 1057).

1049 Longitudinal marking to indicate to vehicular traffic the boundary of a traffic lane reserved for pedal cycles or to divide a segregated shared path into the portions used by cyclists and by pedestrians.

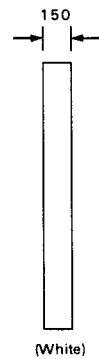

1009 Longitudinal marking to indicate to vehicular traffic the edge of a carriageway at a road junction, or where the line is laid diagonally across a part of the carriageway of a road, to indicate the start of a cycle lane.

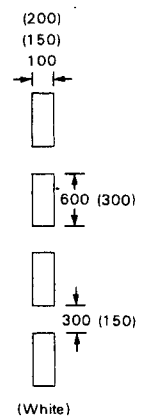

1058 Marking to be used with 1057 marking to indicate the termination of a lane, track or route reserved for pedal cycles.

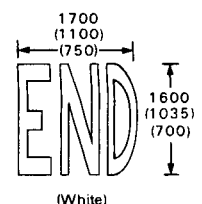

1057 Cycle symbol marking. To indicate a lane, or track for pedal cycles.

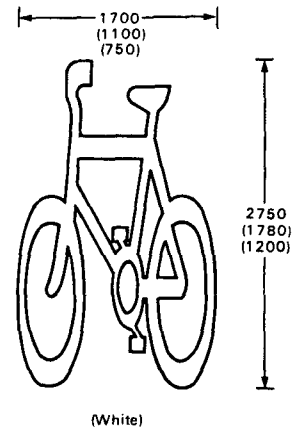

5.2 Upright signs are also needed to give advance warning of the cycle lane and to make it clear that it is reserved for pedal cycles only. Signs to diagrams 812.5 and 654.1 are prescribed to indicate with-flow lanes. The regulatory sign (diagram 654.1) must be directly lit if placed within 50 metres of a system of street lighting and both signs must be reflectorised if not directly lit. The regulatory sign for a contra-flow lane (see also paragraph 5.6) is diagram WBM 653.1, but this sign requires Departmental authorisation before use.

812.5 Lane ahead reserved for pedal cycles proceeding in the same direction as other traffic. (To indicate the effect of a traffic regulation order or similar).

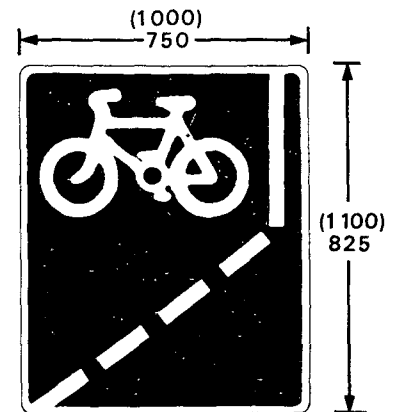

654.1 Lane reserved for pedal cycles when proceeding in the same direction as other traffic. (To indicate the effect of a traffic regulation order or similar).

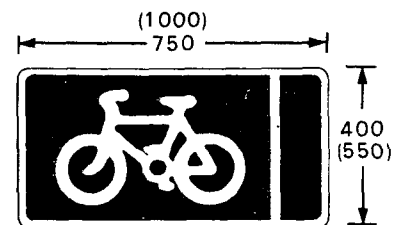

WBM 653.1 One way traffic on either side of the white line, the side of the carriageway to the right of that line being reserved for the use of pedal cycles. (To indicate the effect of a traffic regulation order or similar).

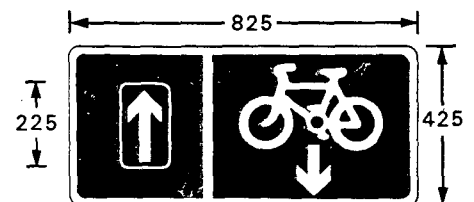

5.3 Since waiting, except for loading/unloading, is prohibited at all times by virtue of a lane which excludes other vehicles, yellow 'no waiting' lines are not necessary in the cycle lane. However, kerb blips and time plates should be

provided to indicate the times when loading is prohibited. In with-flow lanes, a prohibition on loading during the working day should be applied, unless the highway authority is convinced that the frontage development is such that no notable amount of loading will take place from the carriageway. In contra-flow cycle lanes, loading would need to be prohibited at all times.

5.4 On side road approaches to streets which contain with-flow or contra-flow cycle lanes, an informatory sign for traffic should be displayed to diagram 812.6 with the arrow and cycle symbol of the sign in the correct direction. Where with-flow cycle lanes occur on both sides of the carriageway the cycle symbol should be in the direction of travel of the nearest cycle lane, the arrow should be omitted and "Cycle lanes" substituted for "Cycle lane." Where appropriate, the sign should be mounted below any existing regulatory sign prohibiting or requiring a particular turning movement.

812.6 To inform traffic in a side road of a lane or lanes in the major road ahead reserved for pedal cycles, or of a cycle track crossing the side road.  
 Permitted variants: The arrow and symbol may be reversed; the arrow may be omitted and where this occurs the words "Cycle lanes" shall be substituted for "Cycle lane"; the words "Cycle track" may be substituted for "Cycle lane" and where there is two way traffic on the cycle track the arrow shall be omitted.

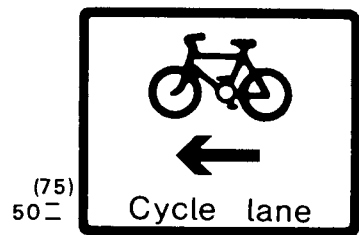

5.5 In providing cycle lanes, it is essential that the interests of pedestrians should be adequately safeguarded. Where kerbside cycle lanes are provided, particularly contra-flow in otherwise one-way streets, informatory signs should be erected at all sites used extensively by pedestrians to cross the road (diagram 810.2 with its permitted variants).

810.2 To inform pedestrians of a lane reserved for pedal cycles, or a cycle track.  
 Permitted variants: The symbol may be reversed in a mirror image and "RIGHT" varied to "LEFT"; "LOOK BOTH WAYS" may be substituted for "LOOK RIGHT"; "CYCLE TRACK" may be substituted for "CYCLE LANE".

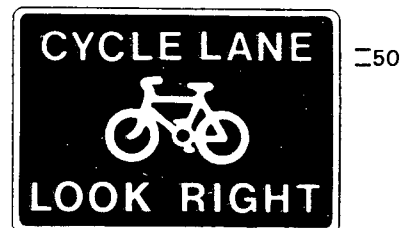

5.6 If a contra-flow lane is proposed, special care will need to be taken to ensure that any danger to cyclists from conflicting movements at the start of the lane is minimised and that along the street the cycle lane is well defined by road markings and upright signs. The direction of travel may be emphasised by the use of the arrow marking (diagram 1059) with the cycle symbol (diagram 1057 - see para. 5.1). Where previously "One-way" plates (diagram 607) have been used beneath signs to diagram 606, the plates will need to be removed on implementation of a contra-flow cycle lane.

1059 Marking to be used with 1057 marking to indicate the direction in which pedal cycles should travel on a lane, track or route reserved for pedal cycles. Permitted variant: The arrow head pointing to the left may be reversed to point to the right.

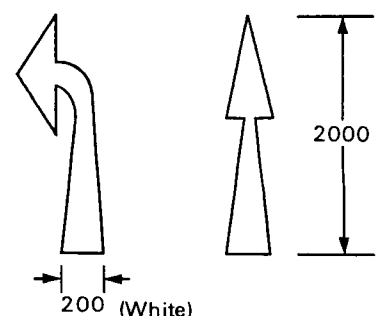

5.7 Plates exempting cycles may be specially authorised for use with signs prohibiting other vehicles from turning right or left (see paragraph 7.2) but should not be used with the 'no entry' sign (diagram 616). This sign is normally associated with one-way systems affecting all vehicles and any misunderstanding about its general application to cyclists could have serious results.

## 6 Advisory Cycle Lanes

6.1 Advisory with-flow cycle lanes should be bounded by a broken hazard line to diagram 1004, but discontinued at each side road junction. The cycle symbol (diagram 1057 – see para. 5.1) should be displayed at the commencement of the lane and after each side road junction. Upright signs to diagram 815 (see para. 3.1) should also be displayed at the start of the lane and then at intervals along the route. Waiting in the lane should be prohibited at all times and loading prohibited during the working day. These restrictions should be indicated as usual by the use of yellow lines, kerb blips and time plates.

1004 Additional use of marking to indicate the boundary of an advisory with-flow cycle lane.

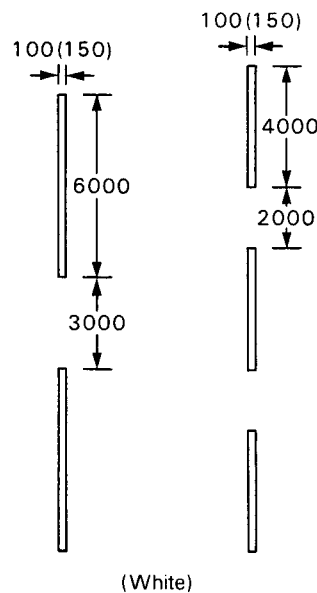

## 7 Streets Where Motor Vehicle Use is Restricted

7.1 Signs to diagram 625 (see para. 9.1) should be used where vehicular access to a street is reserved for cycles only. It is recommended that the signs should be directly lit when used in this situation. When access is also permitted to some motor traffic, the street should normally be signed by the prescribed 'all motor vehicles prohibited' sign (diagram 619) with "Except buses", "Except for loading" or "Except for access" supplementary plates (diagrams 619.3, 619.4 or 620) as appropriate. Alternatively where vehicular access to a street is restricted to buses and cycles only, the positive sign to diagram WBM 267 together with the "only" plate (diagram WBM 267.1) may be used at the entrance points.

WBM 267 and plate WBM 267.1 Route available for buses and pedal cycles only. (To indicate the effect of a traffic regulation order or similar)

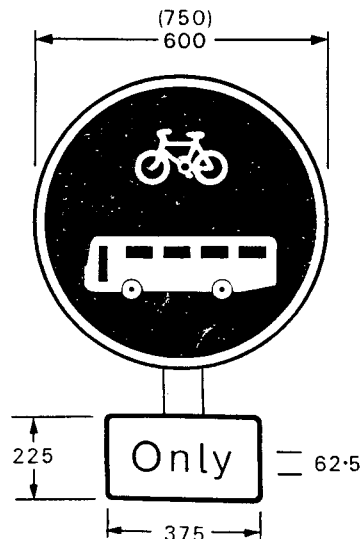

7.2 An 'except cycles' plate may be displayed below a regulatory sign which prohibits or requires specific traffic movements, to enable cyclists to enter a restricted access street. The plate should be to diagram 817.1, which is prescribed for use only with signs to diagrams 816, 816.1 and 817: in all other cases Departmental authorisation is required. Where other vehicles are also exempted the word "cycles" should be used instead of the symbol eg "except buses and cycles". Where the regulatory sign and exemption plates are used in association with traffic light signals they must both be internally illuminated and the plates must conform to WBM 619.5 or WBM 358. These worded plates also require Departmental authorisation.

816 No through road for vehicular traffic.

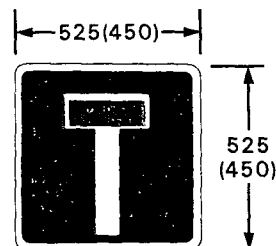

817.1 Plate for use with signs in diagrams 816, 816.1 and 817. (See Direction 12).

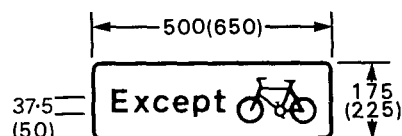

WBM 619.5 Illuminated box, for use with signs shown on drawings No. WM 606, 609, 610, 612, 613, 617, 816, 816.1 and 817.



WBM 358 Illuminated box. (Other permitted variants cover "Except cycles and for loading" and "Except buses, taxis and cycles").

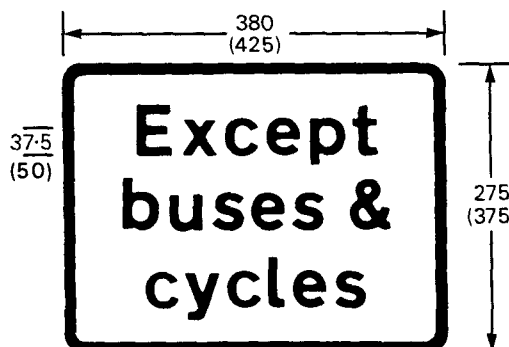

## 8 Cycle Use of Bus Lanes

8.1 Lanes reserved for buses must be marked on the carriageway using diagram 1048, and bounded by markings to diagram 1049. Where, in addition, pedal cycles are permitted to use a with-flow bus lane, advance warning of the lane should be given by a sign to diagram 812.1, used in conjunction with both diagram WBM 1061 and diagram 1049. The lane itself should be signed to diagram 654, again used in conjunction with diagram 1049.

812.1 Lane reserved for buses and pedal cycles ahead.

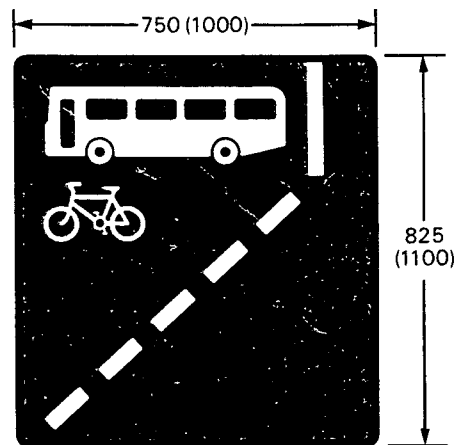

654 Lane marked on the carriageway by the marking in diagram 1048 and bounded by the marking in diagram 1049 reserved for buses and pedal cycles except that any vehicle may cross the line to stop, to load, or unload where this is not prohibited.

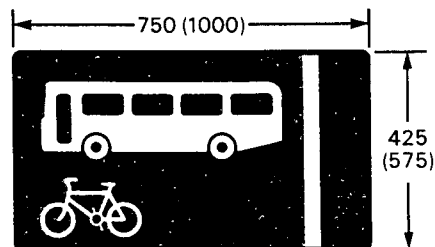

WBM 1061 Bus and cycle lane.

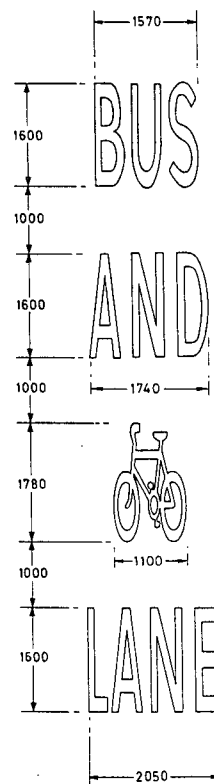

## 9 Cycle Tracks

9.1 Cycle tracks within the meaning of the Highways Act 1980 may either be part of a wider highway, or form a highway entirely distinct from the road system. They should be signed by diagram 625 if they are reserved for cycles only; by diagram 625.3 (see para. 10.2) if they form shared routes for pedestrians and cyclists where the users are segregated; and by WBM 625.5 (which requires Departmental authorisation) (see para. 10.3) if pedestrian and cycle

use is unsegregated. Where the cycle track is reserved for cyclists only or is segregated from the pedestrian route, the sign may be supplemented by the cycle symbol (diagram 1057 – see para. 5.1) marked on the cycle track. The Traffic Signs (Amendment) Regulations (Ref. 2) require a sign to diagram 625 to be lit at night when it is mounted in an illuminated bollard or is within 50 metres of a street light which forms part of a system of street lighting. In all other cases it must be either lit or reflectorised. Even when not required by the Regulations, it is recommended that a 625 sign should be illuminated by steady lighting at the start of a cycle track.

625 Route shall not be used except by pedal cycles  
(To indicate the effect of a traffic regulation order or similar).

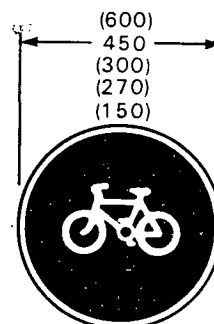

9.2 Where cyclists using a cycle track alongside a carriageway need to cross a minor road, traffic on the minor road can be warned of the presence of the cycle track by the use of sign 812.6 (see para. 5.4) with the permitted variant “CYCLE TRACK”. In most cases cycle tracks operate in two directions and the arrow on the sign should be omitted. The sign must be reflectorised if it is not directly illuminated. Pedestrians can be warned of the presence of the cycle track by the use of sign 810.2 (see para. 5.5) using the permitted variant “CYCLE TRACK”. The caption “LOOK BOTH WAYS” should be used if the cycle track is two way.

9.3 Where a cycle track meets an all-purpose road the prescribed half-size variants of the ‘give way’ markings (diagrams 1003 and if required 1023) should be used. A half-size variant of diagram 1009 (see para. 5.1) is available to complement diagram 1003 for a two-way cycle track at such locations. Where an unsegregated cycle track with pedestrian usage is signed by diagram WBM 625.5 (see para. 10.3) and joins an all-purpose road, the 1003 marking (or variant) should be used across the full width of the track and no markings to diagram 1057 (see para. 5.1) should be put down.

1003 Transverse marking to indicate to vehicular traffic the requirement prescribed by Regulation 22 (2) of The Traffic Signs Regulations and General Directions 1981.

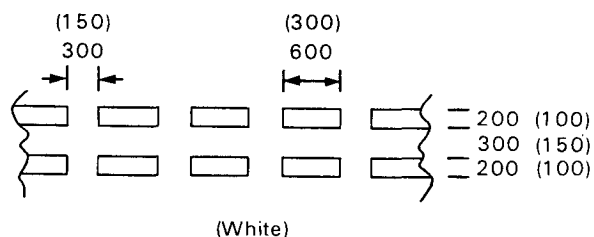

1023 Marking to indicate to vehicular traffic the approach to a road junction at or near which is placed the marking shown in diagram 1003 or both the marking shown in diagram 1003 and the sign shown in diagram 602.

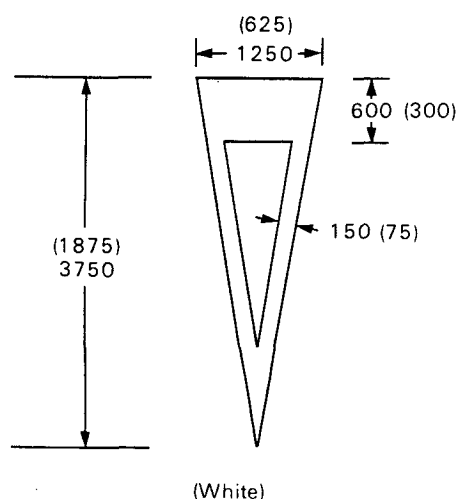

9.4 Where a cycle track alongside a road terminates, with the continuing path being a footway, or where a cycle track diverges from the footway, the offence of cycling on the footway created by Section 72 of the Highways Act 1835 can be indicated by the “no cycling” sign, diagram 624. The sign may also be used to indicate other highways, notably footpaths, on which it is either illegal to cycle, or where a specific offence has been created by virtue of a traffic regulation order or a local bylaw. Where, at particular points along a cycle route, it is undesirable for safety reasons for cyclists to continue riding, they should be advised to dismount by signs to diagram 810.3. In all these cases, and particularly where the advisory sign is used, barriers to encourage dismounting (but allowing for the needs of wheelchairs and prams) are recommended.

- 624 Pedal cycling prohibited.  
(To indicate the effect of a traffic regulation order or similar).

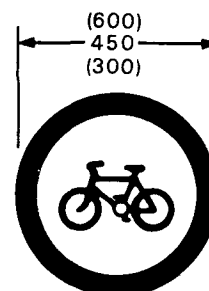

- 810.3 To advise cyclists to dismount at the end of, or at a break in, a cycle track, route or lane.

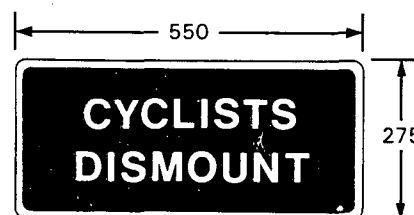

## 10 Shared Routes

10.1 Where local authorities are considering the provision of facilities to be shared by cyclists and pedestrians, it is recommended that they refer to Local Transport Note 2/86 (Ref. 6) for detailed advice on legal, administrative and technical issues.

10.2 For segregated routes the pedestrian and cycle sections should be divided either physically, ie. by means of a barrier or kerb, or by a 150mm wide continuous white line (diagram 1049 – see para. 5.1), or by distinctively coloured surfacing. The sign to diagram 625.3 should be placed at each entrance point and where necessary repeated at intervals along the route. In addition the cycle part of the route should be clearly identified by the display of the cycle symbol marking (diagram 1057 – see para. 5.1) at intervals along the route. It is essential that the signing should be sufficiently comprehensive to ensure that pedestrians and cyclists joining the shared track anywhere along its length are immediately made aware that they are entering a shared facility and which section they should use.

- 625.3 Route comprising two ways separated by a road marking or physical works for use respectively by pedal cycles and pedestrians and by no other traffic.  
Permitted variant: The symbols may be reversed in a mirror image.  
(To indicate the effect of a traffic regulation order or similar).

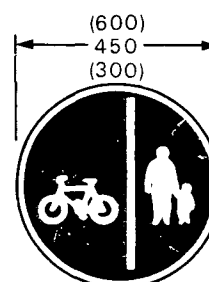

10.3 Where the facility is unsegregated, WBM 625.5 signs (which require Departmental authorisation), should be erected at entrance points and repeated, as necessary, along the route. The cycle symbol marking should *not* be used on unsegregated routes.

WBM 625.5 Unsegregated route available for pedestrians and pedal cycles only. (To indicate the effect of a traffic regulation order or similar).

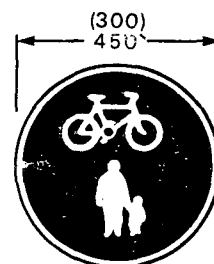

## 11 Directions Signs

11.1 Whatever method is adopted to indicate a cycle route, it is important that cyclists should always be given adequate information about the direction they should take at junctions, or any major deviations in the route. Direction signs for cycle routes off the highway may take the form of diagrams 732.4, 732.5, 739.4, 739.5, or, for routes on highways, may be 'map type' signs to diagram 729.3 or 'stack type' signs to diagram 730.1. The signs in diagrams 732.4 and 732.5 may also be used for routes on highways.

732.4 Direction of route recommended for pedal cycles and mileage to place named.  
Permitted variant: mileage may be omitted.



732.5 Direction and mileage from junction ahead of route recommended for pedal cycles, or pedal cycles and pedestrians, to place named.  
Permitted variants: mileage may be omitted; pedestrian symbol may be added.



739.4 Direction of route for pedestrians and pedal cycles to local places where this differs from the route for other vehicular traffic.  
Permitted variant: The disabled persons symbol may be added in white between the other symbols.



739.5 Direction of route for pedestrians and pedal cycles to railway station where this differs from the route for other vehicular traffic.  
Permitted variants: The British Rail or London Transport symbol may be omitted as appropriate.



729.3 Junction ahead where the route recommended for pedal cycles is different from the route for other vehicular traffic.

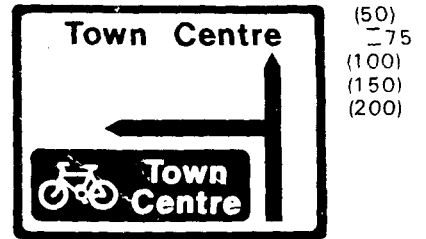

730.1 Junction ahead where the route recommended for pedal cycles is different from the route for other vehicular traffic.



## 12 Advisory Crossing of Minor Roads

12.1 The presence of cycle routes crossing minor roads can be indicated on the carriageway by a special road marking to diagram WBM 294. The prescribed half-size 'give-way' markings (diagrams 1003 – see para. 9.3 and 1009 – see para. 5.1) should also be applied as appropriate on the cycle route. It must be stressed that the cycle crossing marking is purely informatory and does not confer any priority for cyclists. Junctions between cycle routes on low traffic flow roads and other roads should be marked as for a normal "give way" situation.

WBM 294 Marking to indicate a cycle route crossing of a road where no priority is given to on-route pedal cycles and for use in a signalled junction where site conditions make the marking of a cycle route operationally desirable.

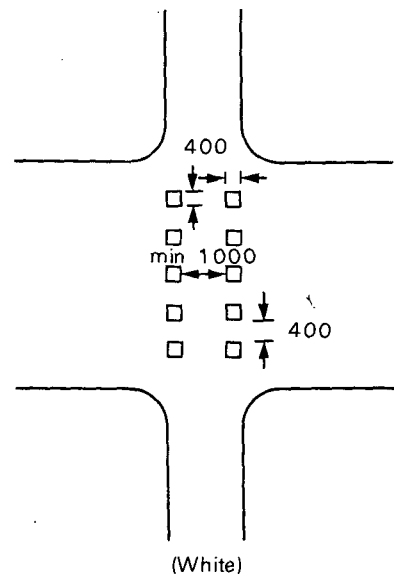

12.2 Warning signs to diagram 544.3 should be provided where necessary on the road approaches to a crossing or junction with a cycle route. The sign should be placed 45m from the crossing or junction when on a 30 mph speed restricted road and with a clear visibility distance of 60m. The sign must be directly lit if placed within 50 metres of a system of street lighting, otherwise it must be reflectorised. Signs to diagrams 812.6 (see para. 5.4) and 810.2 (para. 5.5) may be erected on the approach to an advisory cycle crossing if considered necessary.

544.3 Cycle route ahead.

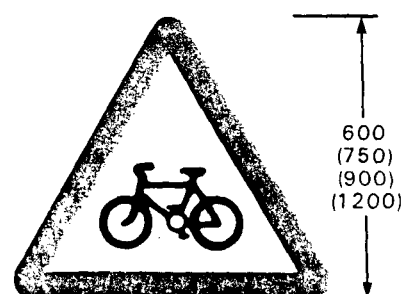

### 13 Major Road Crossings

13.1 Detailed guidance on the signalling of junctions in order to provide for cyclists is given in Section 5B of Local Transport Note 1/86 (Ref. 5). Where cycle-only stages are provided at traffic signals, the amber and green roundels should show a cycle symbol in the appropriate colour with a black background on a 210mm diameter lens. These signals will require Departmental authorisation. There may be exceptional circumstances where consideration may be given to using 300mm diameter amber and green aspects and possibly fibre optic systems. The cycle symbol must never be applied to the red signal.

Traffic signal heads used at cycle crossings.

[authorisation is required for the amber and green cycle silhouettes]

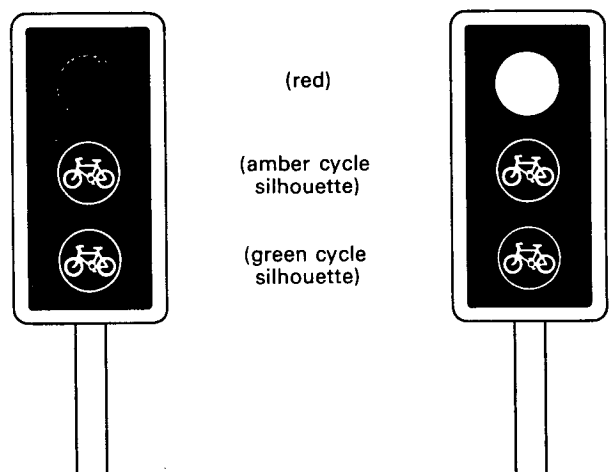

13.2 Road markings should not usually be used to indicate the route cyclists should take through a junction under traffic signal control, but where the particular site conditions make the definition of the cyclists' route desirable, the use of the marking to diagram WBM 294 (see para. 12.1) may be authorised for this purpose.

### 14 Parking Places

14.1 Parking places for various classes of vehicle are signed by diagram 801, with an additional plate to indicate the class of vehicle; in the case of cycles this is diagram 804.4. If desired this plate can be mounted alongside a sign 801 of the smallest size prescribed (instead of below it), to form a composite sign. Where a signed cycle route leads to a parking place for pedal cycles, directions signs 735.1 and 735.2 may be used. Where the cycle parking is reached by an all-purpose road, signs 734.8 and 734.9 should be used with the inclusion of the diagram 804.4 cycle symbol, or combination of another specified symbol and the cycle symbol, in place of the word "Free" on the two signs.

801 and Plate 804.4 for use alongside sign diagram 801 to indicate a parking place for pedal cycles.

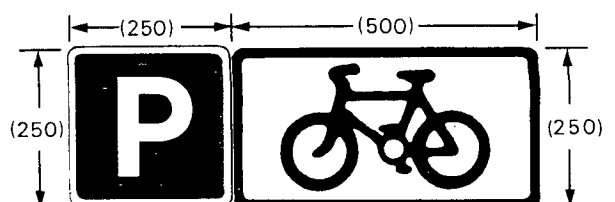

801 and Plate 804.4 for use beneath sign diagram 801  
 804.4 to indicate a parking place for pedal cycles.

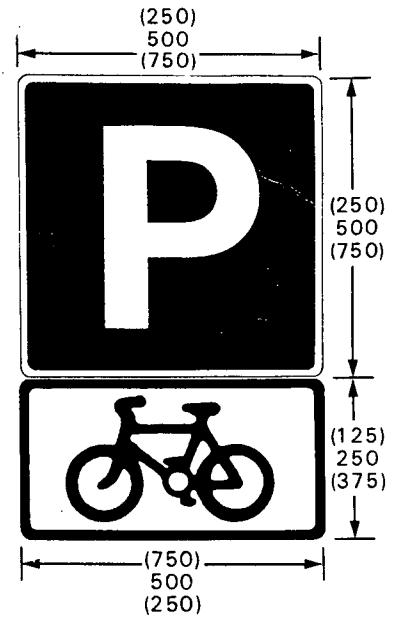

735.1 Direction and distance along a cycle route to a parking place for pedal cycles.  
 Permitted variants: The word "Free" or the distance or both may be omitted.



735.2 Direction along a cycle route to a parking place for pedal cycles.  
 Permitted variant: The word "Free" may be added below the cycle symbol.

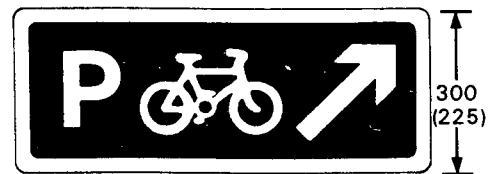

734.8 Permitted variant to indicate the direction and distance along an all purpose road to a parking place for pedal cycles. If the parking place is used for other vehicles, the other appropriate symbol (as listed in Ref. 1) should also be incorporated.

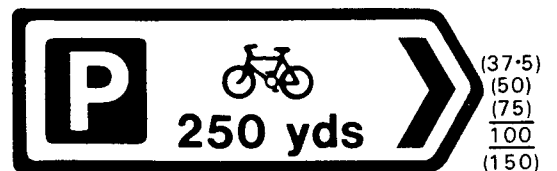

734.9 Permitted variant to indicate the direction along an all purpose road to a parking place for pedal cycles. If the parking place is used for other vehicles, the other appropriate symbol (as listed in Ref. 1) should also be incorporated.

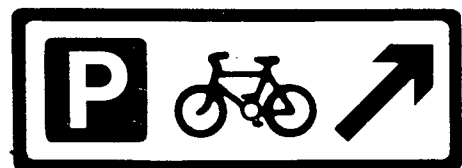

### 15 Tactile Signs

15.1 Tactile signs, which convey messages to blind and partially sighted people by means of a distinct textured pattern in the pavement surface, are traffic signs and are regulated in the same way as visual signs. Those used in

connection with cycle facilities are still under development and none is at present prescribed for use without special Departmental authorisation. The enquiry points detailed on the cover sheet will be glad to give up-to-date advice.

## **16 Mopeds**

16.1 Section 1 of the Cycle Tracks Act 1984 removed the right of mopeds to use cycle tracks, and section 2 of the Act made it an offence for them to do so. All traffic signs which use the cycle symbol are now specifically defined in terms of "pedal cycles". Where a local authority wishes to create a facility for use by pedal cycles and mopeds, an all purpose highway has to be created with its use restricted by a traffic regulation order to pedal cycles and mopeds. The facility should be signed to diagram 625 (see para. 9.1) with a supplementary "and mopeds" plate to diagram 625.2. The Department has not departed from the general advice that mopeds should be excluded from cycle facilities.

## Appendix

### References

1. The Traffic Signs Regulations and General Directions 1981 (SI 859): HMSO.
2. The Traffic Signs (Amendment) Regulations 1982 (SI 1879) and The Traffic Signs General (Amendment) Directions 1982 (SI 1880): HMSO.
3. WBM sign drawings obtainable from:  
Roads Engineering Division, Department of Transport, Room 4/95, St Christopher House, Southwark Street, London SE1. Telephone 01-921 4427.
4. Local Transport Note 1/78 "Ways of helping cyclists in built up areas": DoE/DTP Publications Sales Unit, Room 4, Building One, Victoria Road, South Ruislip, Middlesex, HA4 0NZ. Telephone 01-622 3316.
5. Local Transport Note 1/86 "Cyclists at Road Crossings and Junctions": HMSO, ISBN 0 11 550782 5.
6. Local Transport Note 2/86 "Shared Use by Cyclists and Pedestrians": HMSO, ISBN 0 11 550783 3.
7. Traffic Signs Manual, Chapter 3: Roads Engineering Division, Department of Transport, St Christopher House, Southwark Street, London SE1 0TE.

## Annex A

### Signs and Road Markings for Cycle Facilities

#### Prescribed in Traffic Signs Regulations 1981

No.	Description	Illustrated at para.	
		Para.	Page
624	- No cycling	9.4	13
625	- Pedal cycles only	9.1	12
654	- Bus lanes used by pedal cyclists	8.1	11
732.4	- Direction sign	11.1	14
801	- Parking place sign	14.1	16, 17
812.1	- Bus lanes used by pedal cyclists: advanced warning	8.1	11
815	- Recommended route for pedal cycles	3.1	5
817.1	- 'except cycles' plate	7.2	10

#### Prescribed in Traffic Signs (Amendment) Regulations 1982

No.	Description	Illustrated at para.	
		Para.	Page
544.3	- Cycle route ahead	12.2	15
625	- Pedal cycles only (additional sizes)	9.1	12
625.3	- Segregated, shared pedestrian/pedal cycle route	10.2	13
654.1	- With-flow cycle lane	5.2	7
729.3/730.1	- Direction signs including different route for pedal cycles	11.1	15
732.4	- Direction sign (additional size)	11.1	14
732.5	- Direction from junction ahead of cycle or cycle and pedestrian route	11.1	14
734.8/734.9	- Direction along all-purpose road to cycle parking place (additional variants of signs prescribed in 1981 Regulations)	14.1	17
735.1/735.2	- Direction along cycle route to cycle parking place	14.1	17
739.4/739.5	- Direction of routes for pedestrians and pedal cycles	11.1	14
804.4	- Cycle symbol plate for use with 801	14.1	16, 17
810.2	- Information for pedestrians about a cycle lane or track	5.5	8
810.3	- Cyclists dismount	9.4	13
812.5	- Advance sign for with-flow cycle lane	5.2	7
812.6	- Warning for side road traffic	5.4	8
1003/1023	- 'give way' road markings (additional sizes of markings to those prescribed in 1981 Regulations)	9.3	12
1004	- Boundary of an advisory with-flow lane marking (additional use for markings to that prescribed in 1981 Regulations)	6.1	9
1009	- Edge of carriageway at junction (additional size of markings for use with diagram 1003) Start of cycle lane (additional use for prescribed marking)	5.1	6
1049	- Lane boundary (additional size and use for the marking originally prescribed in 1981 Regulations)	5.1	6
1057	- Cycle symbol markings	5.1	7
1058	- "END" marking	5.1	6
1059	- Arrow marking	5.6	8

## PRESCRIBED SIGNS



544.3      624      625      625.3      654      654.1      729.3      730.1



732.4                      732.5                      734.8                      734.9



735.1                      735.2                      739.4                      739.5



801(P), 804.4(PLATE)      810.2      810.3      812.1      812.5      812.6

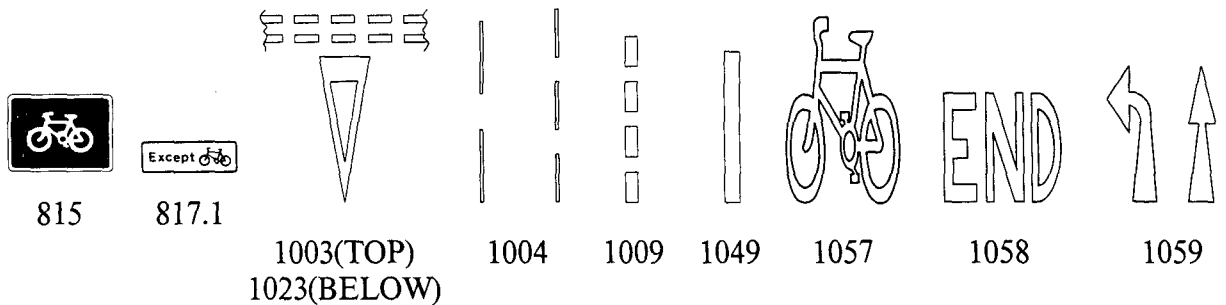

815      817.1      1003(TOP) 1023(BELOW)      1004      1009      1049      1057      1058      1059

## SIGNS NEEDING DEPARTMENTAL AUTHORISATION

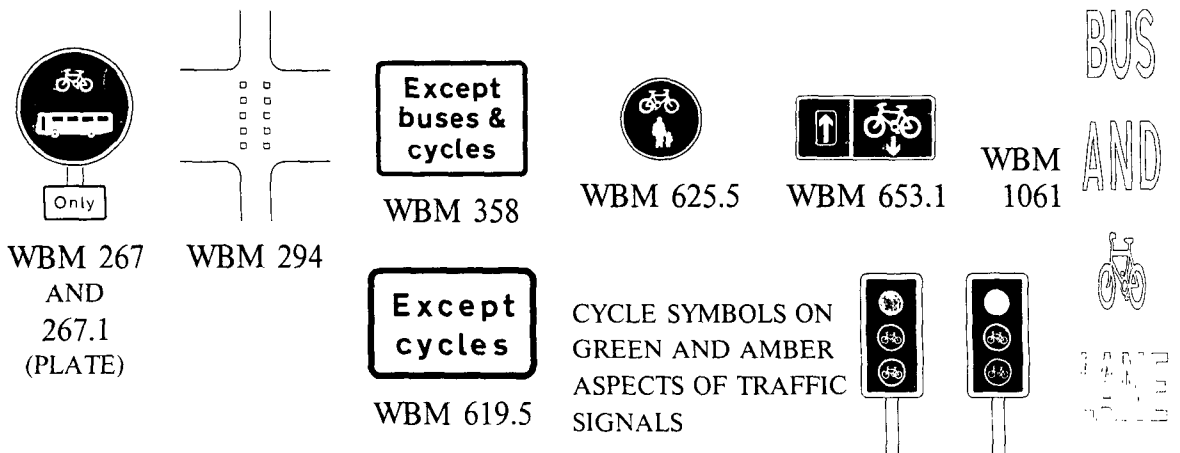

WBM 267 AND 267.1 (PLATE)      WBM 294      WBM 358      WBM 625.5      WBM 653.1      WBM 1061      WBM 619.5      CYCLE SYMBOLS ON GREEN AND AMBER ASPECTS OF TRAFFIC SIGNALS

## Need Departmental Authorisation

No.	Description	Illustrated at para.	
		Para.	Page
WBM 267 & 267.1	Buses and pedal cycles only	7.1	9
WBM 294	Cycle crossing marking and (exceptionally) cycle route within controlled junction	12.1	15
WBM 625.5	Pedestrians and pedal cycles only - unsegregated route	10.3	14
WBM 653.1	Contra-flow cycle lane	5.2	7
WBM 1061	Bus and cycle lane	8.1	11
	Cycle symbols on the green and amber lenses of traffic signals	13.1	16
WBM 358/ WBM 619.5	Illuminated boxes	7.2	10



HMSO publications are available from:

**HMSO Publications Centre**  
(Mail and telephone orders only)  
PO Box 276, London SW8 5DT  
Telephone orders 01-622 3316  
General enquiries 01-211 5656  
(queuing system in operation for both numbers)

**HMSO Bookshops**  
49 High Holborn, London, WC1V 6HB 01-211 5656 (Counter service only)  
258 Broad Street, Birmingham, B1 2HE 021-643 3740  
Southey House, 33 Wine Street, Bristol, BS1 2BQ (0272) 264306  
9-21 Princess Street, Manchester, M60 8AS 061-834 7201  
80 Chichester Street, Belfast, BT1 4JY (0232) 238451  
71 Lothian Road, Edinburgh, EH3 9AZ 031-228 4181

**HMSO's Accredited Agents**  
(see Yellow Pages)

*and through good booksellers*

**£3.50 net**

ISBN 0 11 550834 1